

Optical resonators and Gaussian beams

SÉBASTIEN FORGET

Table des matières

I. Présentation	3
II. Lesson	4
1. Open resonators.....	4
1.1. Description and interest of open resonators.....	4
1.2. Longitudinal and transverse modes.....	5
2. Stability.....	7
2.1. Periodical structure of laser cavities.....	8
2.2. Transfer matrices and ABCD law.....	8
2.3. Resonator stability.....	11
3. Gaussian beams.....	15
3.1. Paraxial wave equation and spherical wave.....	15
3.2. Spherical Gaussian wave.....	16
3.3. Physical properties of Gaussian beams.....	19
3.4. Gaussian beams focusing and mode matching.....	21
4. Fundamental Gaussian mode and laser resonator.....	24
4.1. ABCD law and Gaussian beams.....	24
4.2. Two-mirrors resonator.....	25
4.3. Other resonators.....	28
5. High order modes.....	29
5.1. Hermite-Gaussian Modes.....	29
5.2. Laguerre-Gaussian Modes.....	31
5.3. Multimode beams propagation and M^2 factor.....	32
III. Case study	34
1. Preliminary study of the hemispheric resonator.....	34
1.1. Stability.....	34
1.2. Beam profile inside the resonator.....	36
2. "Real life" resonator.....	37
2.1. Optimisation of the cavity.....	37
2.2. Output beam.....	38
2.3. Thermal lensing effects.....	40
3. Longitudinal and transverse modes.....	40
3.1. Longitudinal and transverse modes.....	40
IV. Lesson questions	42
1. Laser beam transformation.....	42
2. Laser beam characteristics.....	42
3. Stability.....	42
4. Energy.....	42
5. Spectral distribution of the longitudinal modes.....	42
Solution des exercices	44
Bibliographie	47

I.Présentation

Module :

Laser and non-linear optics

Auteur(s) :

Sébastien FORGET - Maître de conférence - spécialités : lasers, optique non linéaires, optoelectronique organique - Laboratoire de Physique des Lasers - Université Paris Nord/13

Résumé :

The aim of this module is to describe in detail the spatial and spectral structure of laser beams as a function of the cavity properties. We will also study the stability of a laser cavity and the propagation of Gaussian beams through an optical system.

Mots-clés :

Laser cavity, Gaussian beams, Laser

Pré-requis :

Basics of laser physics

Objectif(s) pédagogique(s) :

Be able to define a laser cavity allowing the desired characteristics to be obtained for the beam, and know how to calculate the evolution of a Gaussian beam in an optical system.

Plan du cours :

- Open resonators
- Stability of laser cavities
- Gaussian beams
- Gaussian fundamental mode and laser cavity
- Higher-order modes
- Conclusion

Conception & production :

Le Mans Université

Licence :

Licence GNU¹

1 - <http://www.gnu.org/licenses/fdl.txt>

II. Lesson

1. Open resonators

Lasers are optical resonators mainly made of three basic elements :

- A light amplifying medium
- A pumping system
- A resonant cavity

The first two points are described in details in another part of the « source » module (« laser : basic principles »). The point of the present course is to deal with the third element to explain how a resonant cavity can impact the properties of laser beams.

1.1. Description and interest of open resonators

a) Introduction

The role of the laser cavity is to allow the oscillation of the optical wave, generally between two mirrors, so that this wave is amplified at each pass through the amplifying medium inside the cavity. The cavity is also used to extract the useful laser beam through the only partially reflecting outcoupling mirror. Finally, the geometry of the cavity specifies the spatial and spectral characteristics of the laser radiation.

b) Why is an open resonator useful ?

The most simple resonator is a parallelepipedic metallic box (each face is a metallic mirror). In such a cavity, a given number of modes could oscillate, and those modes are determined by the boundary conditions for the wavevectors on the faces of the box (each mode is associated with a wavevector \vec{k}_{mnq} with $k_x = m\pi/a$, $k_y = n\pi/b$, $k_z = q\pi/d$ and a, b, d the dimensions of the box).

Let us consider an amplifying medium in such a cavity : the modes will oscillate and amplification will take place. However, the number of oscillating modes (in the amplifying medium spectral bandwidth) has to remain low to produce a coherent radiation.

The calculation of the number of modes in this bandwidth $\Delta\nu$ shows that it is proportional to the cavity volume and inversely proportional to the square of the wavelength. Numerically, if the wavelength is in the microwave domain (10 cm), we found that about 10 modes could oscillate in a 1 GHz bandwidth for a 10 cm large cubic cavity. Nevertheless, if the wavelength is in the optical range (around 1 μm), as many as 10^{11} modes could oscillate in the same cavity !

This is the reason why such closed resonators are well-tailored for MASERS (Microwave Amplification by Stimulated Emission of Radiation) but cannot be used with visible light : too many modes will oscillate, or in other terms a quasi-monomode operation will require a very small cavity (around 1 μm).

Remarque

With the current technology, such a microcavity is possible – which was not the case in the sixties. However, the amplifying medium is then so small that no powerful laser sources could be considered.

Consequently, one has to modify the resonator geometry : the idea proposed and developed among others by Schallow and Townes in the fifties is to use a quasi-linear resonator where

oscillation is possible only along a single axis : this kind of « **open resonator** » is in its simplest form composed of two spherical or flat mirrors facing each other in a Fabry-Pérot interferometer configuration.

In a first approach, the modes of this resonator are similar to the closed cavity ones with $d \gg a, b$. Such a Fabry Pérot structure considerably reduces the number of oscillating modes : every optical ray having an important angle with respect to the cavity axis will rapidly escape. However, in a Fabry Perot configuration, the facing flat mirrors have to be perfectly parallel to avoid that all the rays escape the cavity after a few round-trips. To ensure efficient laser operation (and to allow spatial and spectral filtering), some rays have to stay in the cavity long enough : *stable* cavities are needed (we will come back to this concept later).

c) Some optical resonators

The simplest optical cavity is a linear cavity composed of two facing mirrors separated by a distance d . The curvature radii are R_1 and R_2 , and the diameters D_1 et D_2 (see figure 1). In this kind of optical cavity, a stationary wave takes place between the mirrors. Some optical elements (lenses, polarisers, active components...) could eventually be inserted inside the cavity. We will call « passive cavity » the optical cavity without the amplifying medium, whereas the « active cavity » will include the amplifying medium.

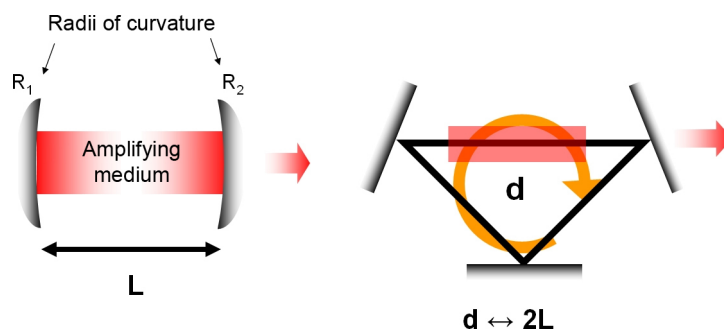

Remarque

A key parameter is the optical path [d] for a roundtrip inside the cavity. This optical path is the product of the distance and the refractive index seen by the optical beam.

Remarque

Another well-known cavity type is the ring cavity, where the light does not form a stationary wave but a progressive one. In this text, we will only deal with linear cavities, but the principles and methods are applicable for every resonator.

1.2. Longitudinal and transverse modes

We can define the open resonator modes by using the expressions found for closed resonators : in the case of a parallelepipedic cavity (the sides of the box have a length a, b and c respectively), the ν_{mnq} resonant frequencies are given by :

$$\nu_{mnq} = \frac{c}{2} \left[\left(\frac{m}{a} \right)^2 + \left(\frac{n}{b} \right)^2 + \left(\frac{q}{d} \right)^2 \right]^{1/2}$$

where c is the speed of light in vacuum and m, n, q are integers..

In the case of an open resonator, $d \gg (a, b)$ and if we take $a = b$ to simplify the formula, we obtain :

$$\nu_{mnq} = \frac{qc}{2} d \left[1 + \frac{(n^2 + m^2)}{a^2} \frac{d^2}{q^2} \right]^{1/2}$$

or after a Taylor expansion

$$\nu_{mnq} \approx q \frac{c}{2d} + (m^2 + n^2) \frac{cd}{4} qa^2$$

This expression gives the TEM_{mnq} modes frequencies.

- The frequencies of the longitudinal modes (TEM_{00q}) are (see figure 2) :

$$\nu_q = q \frac{c}{2d} \text{ (this type of mode are also sometimes called "spectral modes")}$$

One mode ν_{mnq} = three parameters m, n, q

– m, n = transverse modes

– q = longitudinal modes

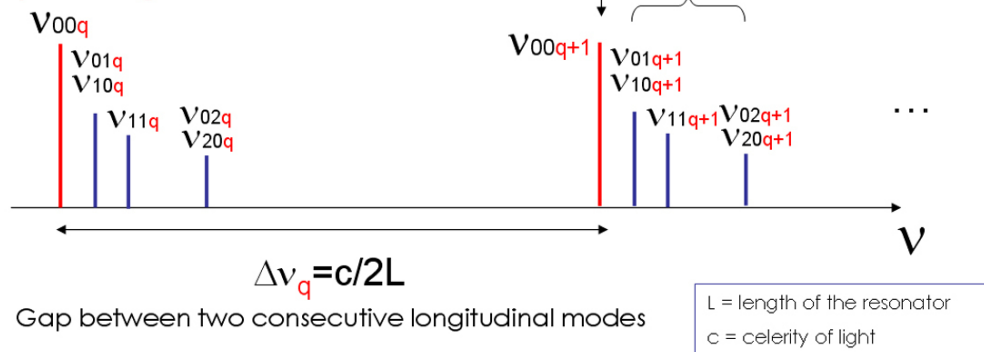

The spectral interval between two longitudinal modes is consequently $\Delta\nu_q = c/2d$, that is 1.5 GHz for $L = 10$ cm fréquentiel de 1.5 GHz.

Définition

A laser with a single well-defined frequency (corresponding to a given value of q) is a "single-longitudinal-mode laser" : only one longitudinal mode could oscillate, and the laser consequently exhibits a high spectral purity (and then an important coherence length)

- The transverse mode are the TEM_{mnq} modes with m and/or n non equal to zero (and generally inferior to 10, because the main goal of an open resonator is to keep the number of oscillating modes small.)

Définition

In a "single-transverse-mode laser", only the TEM_{00q} modes oscillate.

The spectral interval between two transverse modes (n and q fixed) is :

$$\delta \nu_m = (2m + 1) \frac{cd}{4} qa^2$$

The spectral repartition of the longitudinal and the first transverse modes is given in the figure 2.

Remarque

Those results are correct in the plane-wave approximation. We will see later that the expressions have to be modified in the case of Gaussian beams.

Exemple : Example : Orders of magnitude and numerical examples.

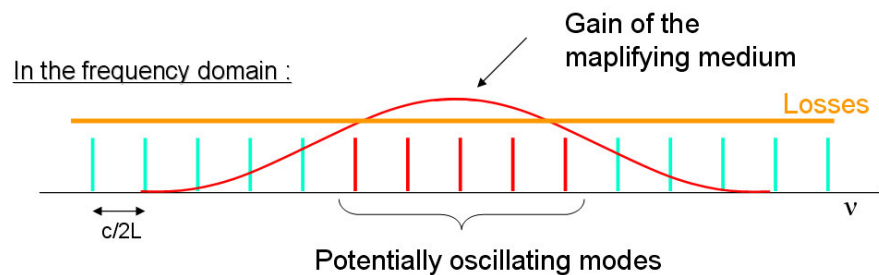
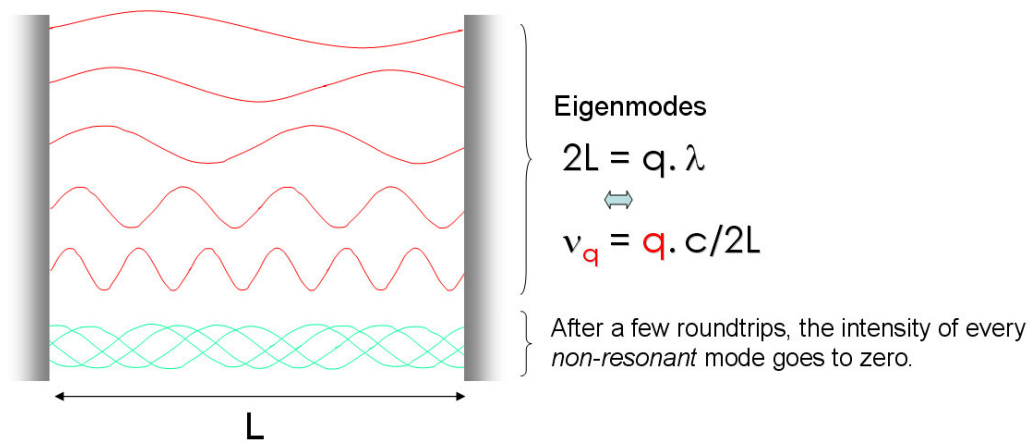

What is the spectral width of a (slightly) multimode laser ? And what about a single-mode one ?

Let L be the length of a given optical cavity. The gap between two consecutive modes is $c/(2L)$, that is 1 GHz if $L = 15$ cm. If we assume that 5 modes are allowed to oscillate (see figure 3), we obtain a spectral width of 5 GHz (or 17 pm in terms of wavelength). This gap is too small to be detected by classical spectrometers, and the laser appears to be monochromatic (even it is not strictly single-mode)

For some applications (metrology...), very narrow laser spectra are needed : it is then possible to force the single-mode behaviour (for example by lowering the losses for only one of the modes) The spectral bandwidth is then the natural width of a single laser line, which depends of the nature of the laser medium (gas, solid...) : the order of magnitude could vary from a few Hz to several MHz.

2. Stability

We will describe here a simple approach based on geometric optics, before following a more exact description based on Maxwell equations (see the paragraph about gaussian beams).

For the sake of clarity, we will consider here only passive cavities : the real cavity could generally be considered as a passive one with some reasonable hypothesis (for example, the thermal effects caused by pump heating inside a laser crystal can be simulated with a simple lens). As usual in the context of geometric optics, the light propagation is described in terms of "rays", defined at each point of a given wave as the direction normal to the wavefront. This is also the energy direction (Poynting vector). Finally, we will only consider centred systems with axial symmetry : the majority of the real cavities are of that kind, at least in a first order approach. We will work with paraxial rays, that is all the rays that are nearly parallel to the optical axis.

2.1. Periodical structure of laser cavities

Let us consider the cavity described in figure 1. An optical ray bouncing back and forth in this cavity could be "unfolded" along the z axis. In other words, the light trajectory could be seen as a series of one-way paths from M_1 to M_2 then from M_2 to M_1 etc. To do that, we only need to replace the mirrors (with radii of curvature R_i) by lenses (with focal lengths $f_i = R_i/2$ - see a basic course about ray optics)

The structure equivalent to a two-mirrors linear cavity is then a periodic structure made of a series of lenses spaced by the distance d (see figure 4)

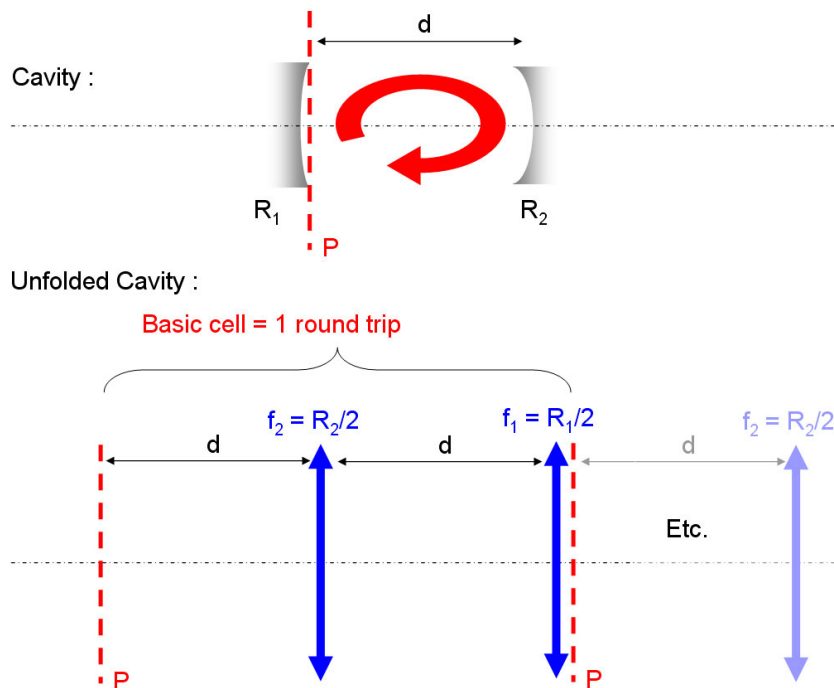

We can then intuitively figure out what is the stability of the cavity : if after passing through the series of lenses the rays remain in the vicinity of the optical axis, the cavity will be stable. If not, the cavity will be unstable.

2.2. Transfer matrices and ABCD law

a) Introduction

Even if obtaining an efficient laser with unstable cavities is possible in some special cases (see later), it is generally more favourable to have a stable resonator. The theoretical study of the stability is the first step before designing any laser cavity (choice of the curvature radii, size of the cavity...).

b) The transfer matrices

The study of the resonator stability is made through the use of so-called "transfer matrices" (or *ABCD* matrices)

The principle of this method is the following : each optical element (lens, mirror, or even simple propagation into any kind of media, including air) is associated with a specific 2×2 matrix. The propagation characteristics could then be obtained very simply by multiplying the basic matrices.

Let's consider a beam propagating in the yOz plane, Oz being the cavity axis. In this plane, a given ray is characterized by its y -coordinate for $z = 0$ (h) and by the slope θ between the direction of the ray and the z axis (see figure 5).

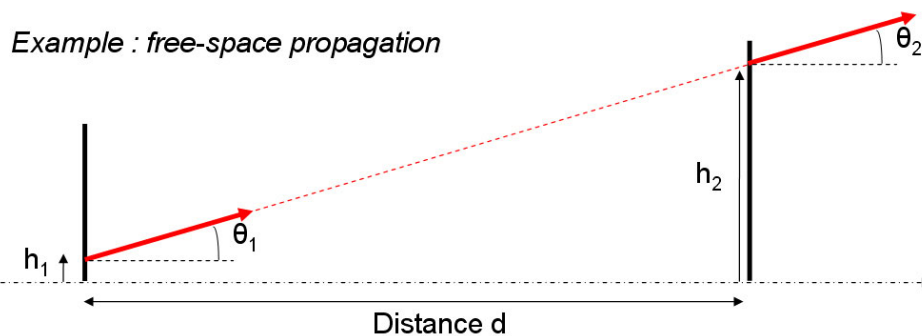
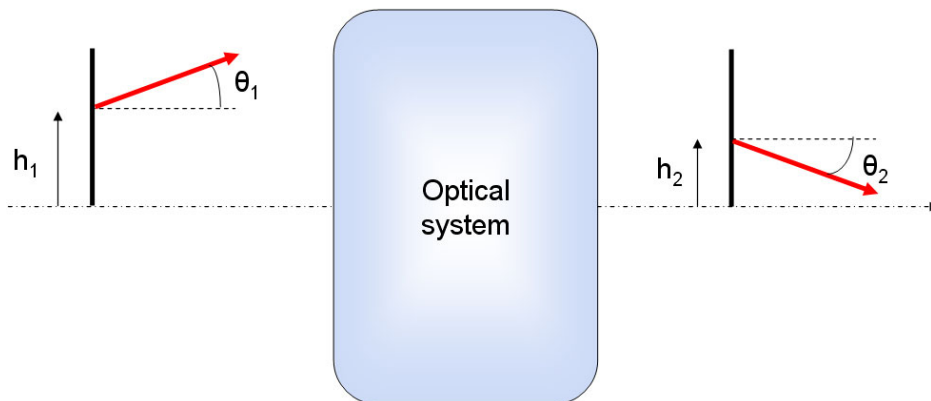

In the Gauss conditions, the relations between (h_1, θ_1) before a given optical system and (h_2, θ_2) after passing through this system are linear, and could be expressed in a matrix form :

$$\begin{pmatrix} h_2 \\ \theta_2 \end{pmatrix} = \begin{pmatrix} A & B \\ C & D \end{pmatrix} \begin{pmatrix} h_1 \\ \theta_1 \end{pmatrix}$$

where the diagonal elements have no dimension, B and C being respectively a length and the inverse of a length.

The matrix $T = \begin{pmatrix} A & B \\ C & D \end{pmatrix}$ fully characterise the optical system

We will then give the basic $ABCD$ matrices for some very useful elements, and show how to get the $ABCD$ matrix of the full system from these elements.

- Propagation over a distance d

$T = \begin{pmatrix} 1 & d \\ 0 & 1 \end{pmatrix}$ The demonstration is straightforward (see figure 5) :

$h_2 = h_1 + d\theta_2$ et $\theta_2 = \theta_1$ (because the rays are paraxial, we can assume $\tan x = x$)

$$h_1 = Ah_2 + B\theta_2$$

If we develop the matrix relation given above, we obtain : $\theta_1 = Ch_2 + D\theta_2$

We can then deduce by identification : $A = 1, B = d, C = 0$ et $D = 1$.

We will not demonstrate the other relations (the argument is exactly the same) : this is a good exercise !

- Propagation over a distance d in a medium (index of refraction n)

$$T = \begin{pmatrix} 1 & \frac{d}{n} \\ 0 & 1 \end{pmatrix}$$

- flat diopter between two media (refractive indexes n_1 and n_2)

$$T = \begin{pmatrix} 1 & 0 \\ 0 & \frac{n_1}{n_2} \end{pmatrix}$$

- Thin lens (focal length f)

$$T = \begin{pmatrix} 1 & 0 \\ -\frac{1}{f} & 1 \end{pmatrix}$$

- Mirror (radius of curvature R)

$$T = \begin{pmatrix} 1 & 0 \\ -\frac{2}{R} & 1 \end{pmatrix}$$

We find again here the equivalence between a mirror and a lens with $R = 2f$ (see above).

Attention

Generally speaking, for an optical system S made of N systems in a row ($S_i (i = 1, 2, \dots, N)$), each of them being characterized by a matrix T_i , the matrix T corresponding to the whole system S is the product of the matrices of each element, in the reverse order : $T = T_N \dots T_i \dots T_3 T_2 T_1$

The matrices do not commute, so the order is really important !

We will see in the *C* paragraph that this method could be used not only with geometric optics, but also with Gaussian beams.

Remarque

Some laser cavities use astigmatic components (off-axis spherical mirrors, Brewster plates, cylindrical lenses, prisms...) : in this case, the calculation has to be done for each orthogonal direction (x and y), because the matrices are not the same for x and y !

c) ABCD law

The *ABCD* law describes the propagation of a spherical wave through an optical system.

Let's consider a spherical wave with its origin at O_1 , and a radius of curvature R_1 at the entrance of a given optical system. This wave converges toward the point O_2 after the system, with a radius R_2 . We will take $R > 0$ for diverging waves and $R < 0$ for converging ones.

With this convention, $R_1 \approx h_1/\theta_1$ et $R_2 \approx h_2/\theta_2$ (see figure 6)

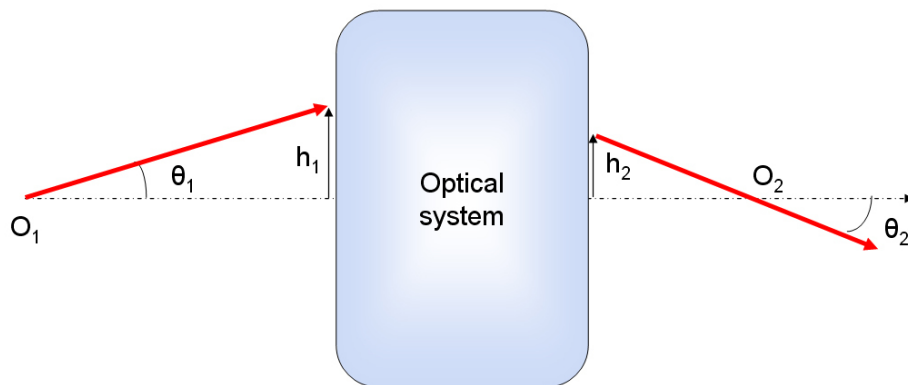

We can thus deduce from the definition of the *ABCD* matrix :

$$R_2 = \frac{AR_1 + B}{CR_1 + D}$$

This relation is very important. We will see that it can be also applied to complex radii of curvature (see the chapter dealing with Gaussian beams)

2.3. Resonator stability

a) General study

Let's study a cavity with a periodic structure of optical elements as described before. Its

transfer matrix is $T = \begin{pmatrix} A & B \\ C & D \end{pmatrix}$

For n periods, that is n round trips inside the cavity, the transfer matrix is T^n . If we write

$p_0 = \begin{pmatrix} h_0 \\ \theta_0 \end{pmatrix}$ the vector representing an optical ray at the entrance of a period, and $p_n = \begin{pmatrix} h_n \\ \theta_n \end{pmatrix}$ the exit vector, then, $p_n = T^n \cdot p_0$

T can be diagonalized, and if P is the transition matrix and x_i the eigenvectors of T , we can

show that $T = P \begin{pmatrix} x_1 & 0 \\ 0 & x_2 \end{pmatrix} P^{-1}$ (see a course on linear algebra).

We can then deduce that

$$p_n = P \begin{pmatrix} x_1^n & 0 \\ 0 & x_2^n \end{pmatrix} P^{-1} p_0$$

The resonator is stable if the rays stay in the vicinity of the optical axis during the propagation when n goes to infinity. In other words, p_n must have an upper bound, that is $|x_1| \leq 1$ and $|x_2| \leq 1$.

In addition, the eigenvalues x_1 and x_2 verify the following relations :

$$x_1 x_2 = |T| = 1 \quad (T \text{ is unitary})$$

$$x_1 + x_2 = \text{Trace}(T) = A + D$$

As x_1 is a priori a complex number, we write $x_1 = |x_1| e^{i\phi}$ and consequently $x_2 = |x_1|^{-1} e^{-i\phi}$. Then, as $|x_1| \leq 1$ et $|x_2| \leq 1$, we must have $|x_1| = |x_2| = 1$. Finally, the relation with the matrix trace leads to $2 \cos \phi = A + D$.

We deduce from this **the stability condition, applicable to any resonator** :

$$-1 \leq \frac{A+D}{2} \leq 1$$

or

$$0 \leq \frac{A+D+2}{4} \leq 1$$

Définition

A resonator is stable when its $ABCD$ coefficients verify the above condition.

b) Application

Let's d be the length of a simple two-mirrors linear resonator (radii of curvature R_1 and R_2). This resonator is equivalent to a periodic sequence made of two thin lenses with focal lengths equal to $f_1 (= R_1/2)$ and $f_2 (= R_2/2)$, spaced by a distance d .

The T transfer matrix is (see figure 4):

$$T = \begin{pmatrix} 1 & 0 \\ -1/f_1 & 1 \end{pmatrix} \begin{pmatrix} 1 & d \\ 0 & 1 \end{pmatrix} \begin{pmatrix} 1 & 0 \\ -1/f_2 & 1 \end{pmatrix} \begin{pmatrix} 1 & d \\ 0 & 1 \end{pmatrix} = \begin{pmatrix} 1 - \frac{d}{f_2} & d(2 - \frac{d}{f_2}) \\ \frac{-1}{f_1} - \frac{1}{f_2} + \frac{d}{f_1 f_2} & (1 - \frac{d}{f_1})(1 - \frac{d}{f_2}) - \frac{d}{f_1} \end{pmatrix}$$

it is then easy to show that

$$\frac{A+D+2}{4} = (1 - \frac{d}{R_1})(1 - \frac{d}{R_2})$$

We classically use the notation $g_i = 1 - d/R_i$ and then obtain **the stability condition for any two-mirrors linear resonator** :

$$0 \leq g_1 g_2 \leq 1$$

This relation is often drawn on a diagram representing the $g_2(g_1)$ space, that is with g_2 as y -axis and g_1 as x -axis (figure 7).

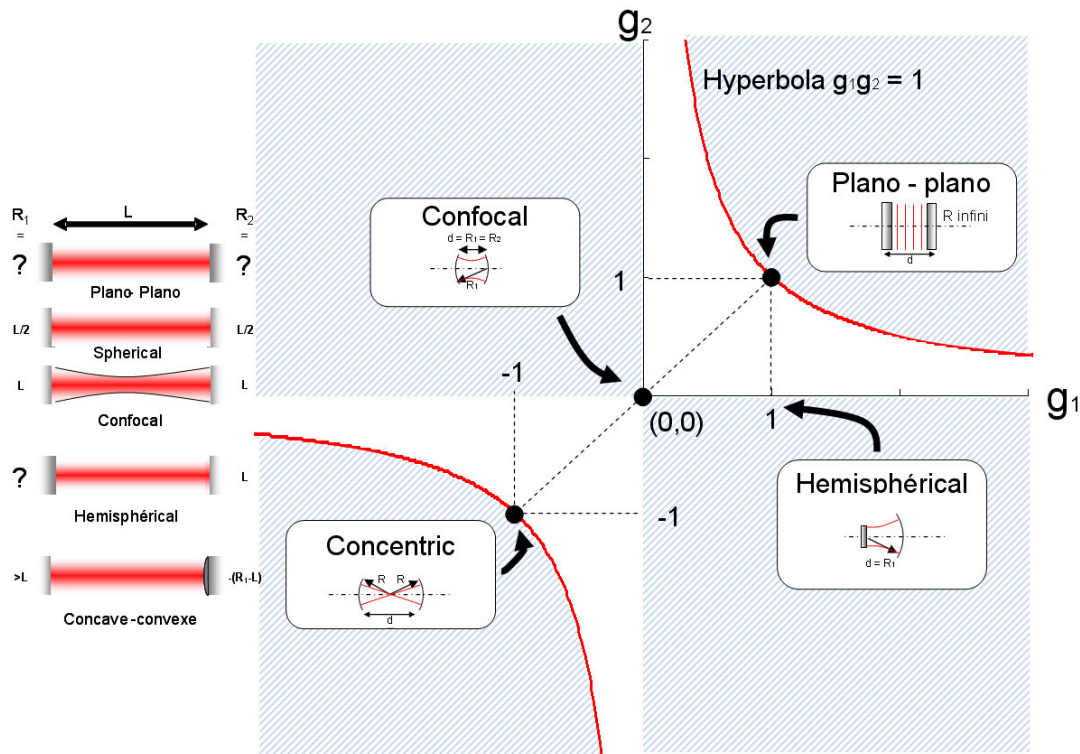

The stability condition is then figured by two hyperboles, and the stability zones are hatched in pale blue on figure 7.

Some special cases have to be noticed :

- Right on the hyperbole $g_1 g_2 = 1$: we have then $d = R_1 + R_2$, and the resonator is "concentric"
- The straight lines $g_1 = 1$ et $g_2 = 1$ correspond to resonators with one plane mirror (infinite radius of curvature). The Fabry-Pérot (plano-plano cavity, that is two plane mirrors) is obtained for $g_1 = g_2 = 1$.
- For $R_1 = R_2 = d$ ($g_1 = g_2 = 0$), the resonator is "confocal".

Remarque

There is a simple graphical method to know if a 2-mirrors resonator is stable or not : the point is to check if two circles (with diameter R_1 and R_2 respectively) centred on the focal points F_1 and F_2 have an intersection (see figure 8). If they do, the cavity is stable. Moreover, the circles intersection gives the position of the waist and the Rayleigh length (those two parameters will be defined in an upcoming paragraph)

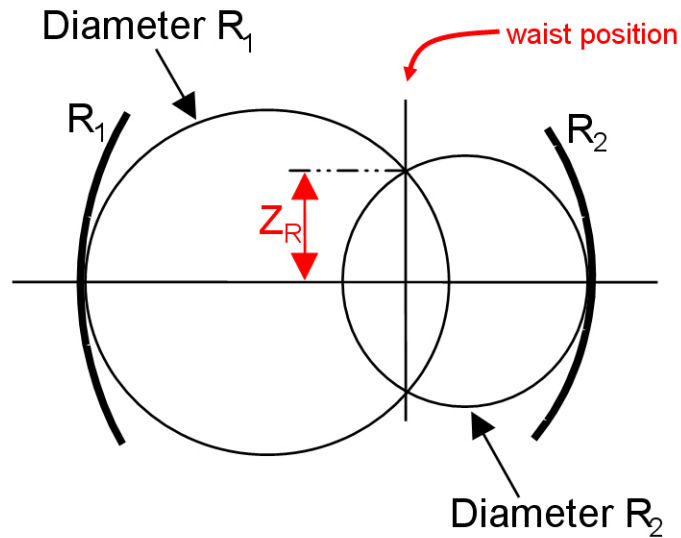

c) Unstable resonators

A stable resonator is not a necessary condition to make a laser. In some cases, if the laser medium exhibits a gain coefficient high enough to allow a high level of losses, unstable resonators can even be very useful. This is for example the case with very high power lasers.

Unstable confocal resonator, $g_1 g_2 > 1$

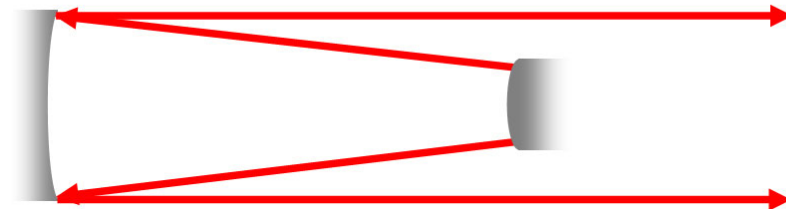

For each round trip, the inclination of the ray increases, until it escapes from the resonator

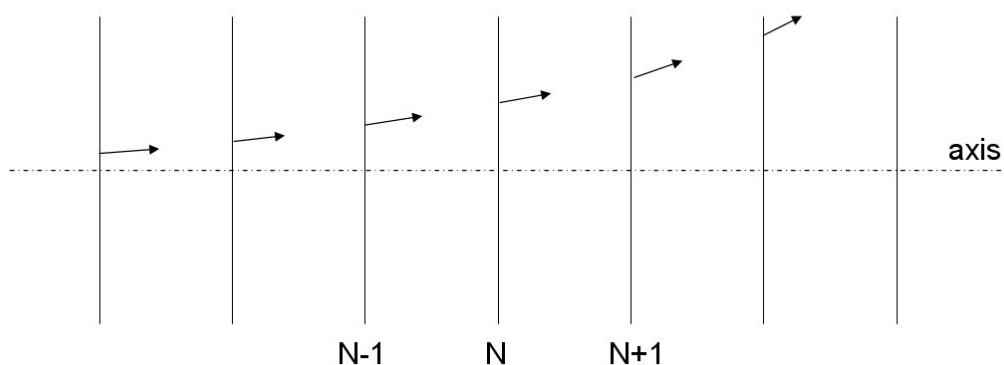

The main advantage of such resonators is that the mode volume in the cavity can be large, which leads to low power densities on the mirrors (for high power lasers, the damage threshold of the mirrors could be easily reached). Moreover, the transverse modes undergo a

high level of losses in an unstable resonator, leading to a natural transverse single-mode operation of the laser.

Those type of resonators are only possible with very high gain systems, because a given ray passes only a few times inside the amplifying medium before escaping from the cavity.

3. Gaussian beams

3.1. Paraxial wave equation and spherical wave.

Any electromagnetic wave propagating inside an homogeneous medium verifies the Maxwell's equations. A direct consequence is that in an isotropic medium the propagation equation is as follows :

$$\Delta \vec{E} - \frac{1}{c^2} \frac{\partial^2 \vec{E}}{\partial t^2} = 0$$

If we consider the propagation of a monochromatic electromagnetic radiation with a frequency $\nu = \omega/2\pi$, we can write this equation in a different manner and show that the wave must verify the **Helmholtz equation** :

$$\Delta E(x, y, z) + k^2 E(x, y, z) = 0$$

where $k = \omega/c$ is the wavevector.

This equation have a very well-known solution : the diverging spherical wave, which can be written :

$$E(x, y, z) = \frac{E_0}{r} \exp(-i k r)$$

where the source is located at $(x, y, z) = (0, 0, 0)$ and r is the distance from the origin.

In the paraxial approximation framework, we assume that the wave propagation is along a specific axis (z -axis). In this case, we can use the following Taylor development :

$$r = \sqrt{x^2 + y^2 + z^2} \approx z + \frac{x^2 + y^2}{2z}$$

The electric field for the position r is then :

$$E_{paraxial}(x, y, z) = \frac{E_0}{z} e^{(-ikz)} e^{(-ik \frac{x^2 + y^2}{2z})}$$

It represents the field for a "paraxial spherical wave", which is only an approximate solution of the Helmholtz equation. We can recognize the propagation factor $\exp(-ikz)$ as well as the transverse variation of the amplitude :

$$\frac{1}{z} e^{(-ik \frac{x^2 + y^2}{2z})}$$

From a mathematical point of view, the spherical wave is a solution of the propagation equation. From a physical point of view, the paraxial spherical wave is an acceptable approximate solution to describe the wave propagation.

However, in our case (that is, for lasers), this wave is not a convenient solution : the energy spreads out in all directions, and when we isolate the paraxial part a great amount of energy is lost, which is not compatible to efficient laser operation. Indeed, the electromagnetic field structure inside an optical resonator should ideally verify the following conditions :

- Verify the Maxwell's equations
- The field amplitude should decrease when the distance relative to the cavity axis increase, to take into consideration the finite dimensions of the mirrors and of the gain medium.
- The wavefront must fit to the radius of curvature of the mirrors (this condition exclude plane waves)

We will now describe the solutions that are well-adapted to laser resonators.

3.2. Spherical Gaussian wave

We will now introduce here a generalization for the solutions of the Helmholtz equation. The physical signification of those solution will be explain afterwards.

For the solutions of the Helmholtz equation corresponding to paraxial beams along the z -direction, we can write :

$$E(x, y, z) = \psi(x, y, z) e^{-ikz}$$

where $\psi(x, y, z)$ is a complex function representing the difference between a laser beam and a homogeneous plane wave.

If we replace this solution in the Helmholtz equation, with the additional hypothesis that the variations of $\psi(x, y, z)$ in the z -direction are small over a distance comparable to the wavelength

(that is $\lambda \left| \frac{\partial \psi}{\partial z} \right| \ll |\psi|$ and $\lambda \left| \frac{\partial^2 \psi}{\partial z^2} \right| \ll \left| \frac{\partial \psi}{\partial z} \right|$), we can write **the paraxial wave equation** in the following form :

$$\frac{\partial^2 \psi}{\partial x^2} + \frac{\partial^2 \psi}{\partial y^2} - 2ik \frac{\partial \psi}{\partial z} = 0$$

Remarque

This equation is similar to the Schrödinger wave equation describing a free particle in a 2D space (just replace the time t by the spatial coordinate z).

The solution of the paraxial wave equation are well-known. We can thus easily check that the following function (among others) is a solution :

$$\psi(x, y, z) = e^{-i[\Delta\phi(z) + \frac{k}{2q(z)}(x^2 + y^2)]}$$

with :

- $\Delta\phi(z)$ is a complex phase difference.
- $q(z)$ represents a complex radius of curvature, or in other words the transverse variation of the amplitude and the wavefront curvature.

This specific solution, called "**fundamental Gaussian mode**", is actually the most important for laser resonators. We will study later this mode more specifically.

By substituting the expression for $\psi(x, y, z)$ in the paraxial wave equation, we obtain that for any (x, y) :

$$\left[\frac{k^2}{q^2} (x^2 + y^2) \left(\frac{dq}{dz} - 1 \right) - 2k \left(\frac{d\Delta\phi}{dz} + \frac{i}{q} \right) \right] \psi = 0$$

We deduce then that $q(z)$ and $\Delta\phi(z)$ must verify :

$$\frac{dq}{dz} = 1 \Rightarrow q(z) = q_0 + z \text{ avec } q_0 = q(0)$$

$$\frac{d\Delta\phi}{dz} = \frac{-i}{q} \Rightarrow \Delta\phi(z) = -i \ln\left(\frac{q_0 + z}{q_0}\right) \text{ si } \Delta\phi(0) = 0$$

If we write $\frac{1}{q(z)} = \frac{1}{R(z)} - i \frac{\lambda}{\pi w^2(z)}$

Then

$$e^{(-i\Delta\phi(z))} = \frac{1}{1 + \frac{z}{q_0}} = \frac{1}{1 + \frac{z}{R_0} - \frac{i\lambda z}{\pi w_0^2}}$$

where the "0" indexes correspond to the values for $z = 0$. If we choose the origin so that the curvature radius is infinite (plane wave) at this point, we have $q_0 = i \frac{\pi w_0^2}{\lambda}$. We can then easily show that :

$$\frac{1}{q(z)} = \frac{1}{q_0 + z} = \frac{1/q_0}{1 + z/q_0} = \frac{1}{1 + \left(\frac{\lambda z}{\pi w_0^2}\right)^2} \left[\frac{1}{z} \left(\frac{\lambda z}{\pi w_0^2}\right)^2 - i \frac{\lambda}{\pi w_0^2} \right]$$

After identification of this relation with $\frac{1}{R} - i \frac{\lambda}{\pi w^2(z)}$ we conclude that :

$$R(z) = z + \frac{Z_R^2}{z} \text{ with } Z_R = \frac{\pi w_0^2}{\lambda}$$

$$w(z) = w_0 \sqrt{1 + \left(\frac{z}{Z_R}\right)^2}$$

Moreover :

$$e^{(-i \Delta \phi(z))} = \frac{1}{1 - \frac{iz}{Z_R}} = \frac{1}{\sqrt{1 + \left(\frac{z}{Z_R}\right)^2}} e^{i \xi(z)} \text{ where } \tan \xi(z) = \frac{z}{Z_R}$$

Fundamental

Finally, if we gather all those equations, we get the fundamental expression of the spherical Gaussian wave :

$$E(x, y, z) = K \frac{1}{w(z)} e^{-ik(z)} e^{i \xi(z)} e^{-ik \frac{(x^2 + y^2)}{2q}}$$

with :

- $K/w(z)$ is a normalization factor
- the first exponential function is the propagation factor
- the second exponential function is a phase difference sometimes called « Guoy » phase shift
- the third exponential function could be broken up in a "spherical wave" factor and a "Gaussian" factor, by replacing q with its expression as a function of R :

$$e^{-ik \frac{(r^2)}{2q}} = e^{-ik \frac{r^2}{2R}} e^{-\frac{r^2}{w^2}}$$

where we have used cylindrical coordinates ($r^2 = x^2 + y^2$),

Here we see the Gaussain shape of the transverse profile of the wave for any z position. The intensity profile (proportional to the square of the field amplitude) is then (see figure 10) :

$$I(r, z) = I_0(z) e^{-2 \frac{r^2}{w^2(z)}}$$

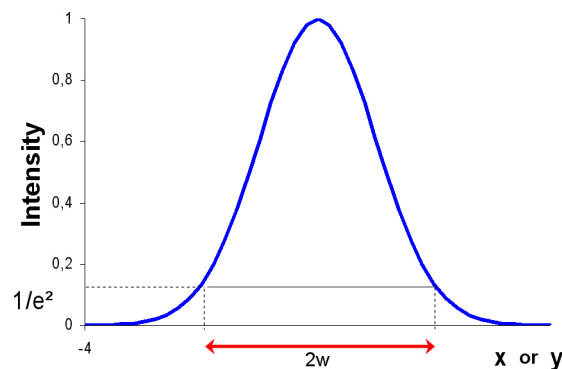

- $R(z) = z \left[1 + \left(\frac{\pi w_0^2}{\lambda z} \right)^2 \right]$ is the radius of curvature of the wavefront at the z abscissa.

- $w(z) = w_0 \sqrt{1 + \left(\frac{\lambda z}{\pi w_0^2}\right)^2}$ is a measure of the Gaussian decrease of the field amplitude with the distance relative to the z -axis (see figure 10). The parameter w is the distance for which the amplitude is equal to $1/e$ times ($1/e^2$ if we consider the intensity) its value for $(x, y) = (0, 0)$

Définition

w is minimal when $z = 0$, where the radius of curvature is infinite. Its value at the origin is written w_0 and defines the "waist" of the beam.

Définition

- $Z_R = \frac{\pi w_0^2}{\lambda}$ is a very convenient parameter called "Rayleigh length" and is related to the beam divergence (see later).

We also remind the following relations :

- $q = q_0 + z$ and $\frac{1}{q} = \frac{1}{R} - i \frac{\lambda}{\pi w^2}$

Définition

- $\tan \zeta = \frac{\lambda z}{\pi w_0^2}$ and $\zeta(z)$ is the Guoy phase shift.
- This phase difference means that the phase of the Gaussian wave is shifted by a quantity $\zeta(z)$ on the z -axis relatively to a plane wave of the same wavelength that have left the $z = 0$ point at the same moment. The wave undergoes a global phase shift of π when passing through $z = 0$.

3.3. Physical properties of Gaussian beams

The main basic expressions related to Gaussian beams were mathematically obtained in the previous paragraph. We will now describe their physical signification.

Let's take again the origin at the waist position w_0 , corresponding to a plane wave (infinite radius of curvature). We have defined the Rayleigh length : $Z_R = \pi w_0^2 / \lambda$.

We also wrote the equation describing the evolution of w versus z :

$$w(z) = w_0 \sqrt{1 + \left(\frac{z}{Z_R}\right)^2}$$

$w(z)$ is an hyperbola (we could also write the previous relation : $\frac{w^2}{w_0^2} - \frac{z^2}{Z_R^2} = 1$).

a) Main useful parameters

Let us remind the main parameters and results previously described :

- $w(z)$ is the dimension of the laser spot (the "radius" if the spot is circular) in the plane perpendicular to the propagation, at a distance z from the origin. Precisely, it is the radius (at $1/e$ for the amplitude, or $1/e^2$ for the intensity) of the transverse Gaussian profile at the z abscissa.

$$I(r, z) = I_0(z) e^{-2 \frac{r^2}{w^2(z)}}$$

- When z increases, the beam expands in the transverse direction while its amplitude on the z -axis decrease (energy conservation). The profile shape remains Gaussian.
- The size of the beam at the origin, w_0 , is minimal : the beam will diverge from this point (see figure 11). This minimal dimension is called "**beam waist**" (the waist is the *radius* of the spot. The diameter is of course given by $2w_0$).
- At the waist, the wavefront is a plane.

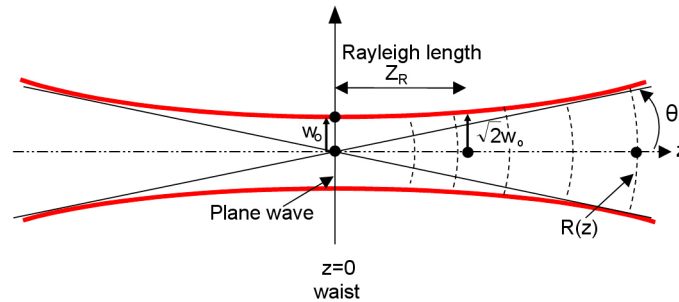

- The beam divergence is given by the limit of w/z when z goes to infinity :

$$\lim_{z \rightarrow \infty} \frac{w}{z} = \frac{w_0}{Z_R} = \frac{\lambda}{\pi w_0} = \tan \theta \quad \text{or for a small divergence} \quad \tan \theta = \frac{\lambda}{\pi w_0} \approx \theta$$
- The Gaussian characteristics of the beam are essentially important in the vicinity of the beam waist. Indeed, when z increases, the complex radius of curvature becomes close to R and the wave could be considered spherical.
- The Rayleigh length is the distance (from the waist) where the beam area is twice the beam area at the waist (the radius is $\sqrt{2}$ times bigger). This parameter is useful to define a "collimated" beam : over this length, the beam size is nearly constant (between w_0 and $w_0 \sqrt{2}$) - see figure 11.

Exemple : Order of magnitude :

For a tightly focused laser beam ($w_0 = 10 \mu$) and a $1 \mu\text{m}$ wavelength, we find $Z_R = 314 \mu\text{m}$ and a divergence (half-angle) of 1.8 degrees.

If we consider a "big" waist (1 mm), we find $Z_R = 3.14 \text{ m}$ and a divergence (half-angle) of 0.018 degrees. We then obtain a so-called "collimated beam".

Fondamental

The divergence of a Gaussian beam is inversely proportional to the size of its waist. In the framework of Gaussian optics, "collimating a beam" is the same thing as "having a big waist".

We observe on figure 12 the evolution versus z of the Rayleigh length and of the divergence for a $1 \mu\text{m}$

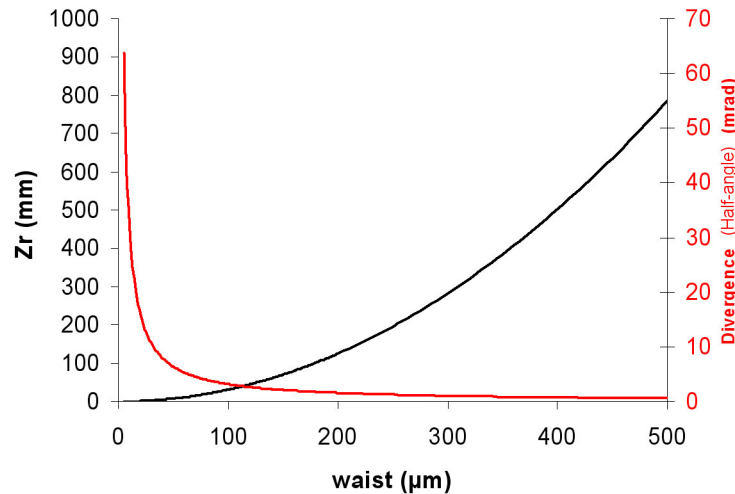

b) Other useful relations

Some very practical relations could be deduced from the previous ones, as for example :

$$w_0^2 = \frac{w^2}{1 + \left(\frac{\pi w^2}{\lambda R}\right)^2}$$

and

$$z = \frac{R}{1 + \left(\frac{\lambda R}{\pi w^2}\right)^2}$$

Those relations are used to find the waist size and its position starting for experimental measurements of R and w .

3.4. Gaussian beams focusing and mode matching

A very common experimental action is to modify a Gaussian beam with a lens. For example, if one wants to inject a given pump laser beam in another laser cavity, it is crucial that the beam "matches" the resonator of this last laser.

When passing through a lens, a Gaussian beam is turned into another Gaussian beam : let's see how.

By using the *ABCD* law (see corresponding paragraph) applied to a centred optical system (with the focal point set as the origin), one can find the relations between positions and sizes of the waists before and after the optical system.

The "object waist" w_0 is located at the abscissa σ relatively to the object focal point, whereas the "image waist" w'_0 is located at the abscissa σ' with respect to the image focal point (see figure 13).

Remarque

The notion of "object" and "image" waist is in fact not rigorously applicable here, because those two points are not conjugated. In other terms, the waist of the image beam is not the

image of the waist of the object beam. We will nevertheless conserve this practical notation in the following.

The complex radius of curvature corresponding to the object waist is imaginary :

$$q_0 = i \frac{\pi w_0^2}{\lambda}$$

The transfer matrix elements of the optical system are (check it !):

$$A = \frac{-\sigma'}{f'} ; B = -f + \frac{\sigma \sigma'}{f'} ; C = \frac{-1}{f'} ; D = \frac{\sigma}{f'}$$

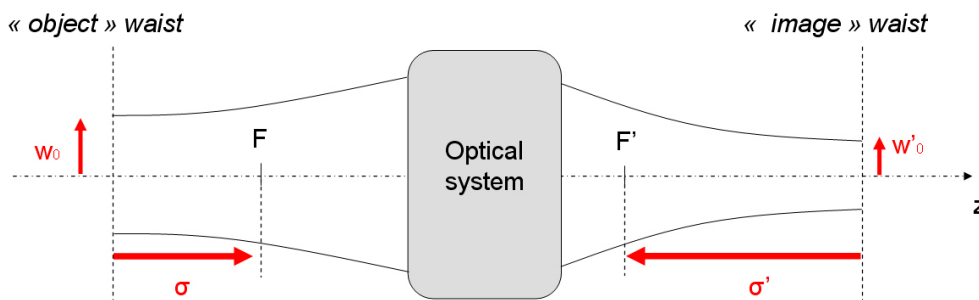

By applying the $ABCD$ law, and using the fact that q_0 and q'_0 are both imaginary, we find the following relations :

$$\begin{aligned} \sigma \sigma' &= ff' - q_0 q'_0 \\ -\sigma q'_0 &= \sigma' q_0 \end{aligned}$$

or in a different form :

$$\begin{aligned} \sigma \sigma' &= ff' + Z_R Z'_R \\ \frac{-\sigma}{Z_R} &= \frac{\sigma'}{Z'_R} \end{aligned}$$

Those relations show that the position of the image waist depend not only on the position of the object waist, but also on its size. In the same way, the size of the image waist is a function of the size and position of the object waist.

- When $\sigma \gg Z_R$, the wave around the focal point is nearly spherical (far field). From the lens point of view, the wave seems to come from a single point, and we have $\sigma \sigma' = ff'$. This is the Newton conjugation relation we used to see in classical geometric optics.
- Another special case is $\sigma = 0$, that is the object waist is located on the focal point of the lens. In ray optics, we expect a collimated beam (parallel rays) after the lens. With Gaussian beams, we have $\sigma' = 0$: the image waist is located on the image focal point.

Attention

It is clear that the "conjugation relations" are very different in classical or Gaussian optics, especially around the focal points. However, we have to remind that the term "conjugation relation" has not the same meaning here and in geometric optics.

The relation of magnification between waists is given in this case by :

$$w'_0 = \frac{\lambda f}{\pi w_0}$$

This relation is very important from the experimental point of view. Indeed, this is a very common configuration (focusing/collimation or the opposite). This relation gives a good order of magnitude to answer the following question : "what will be the size of the laser spot after focusing a nearly collimated beam with a lens (focal length f) ?"

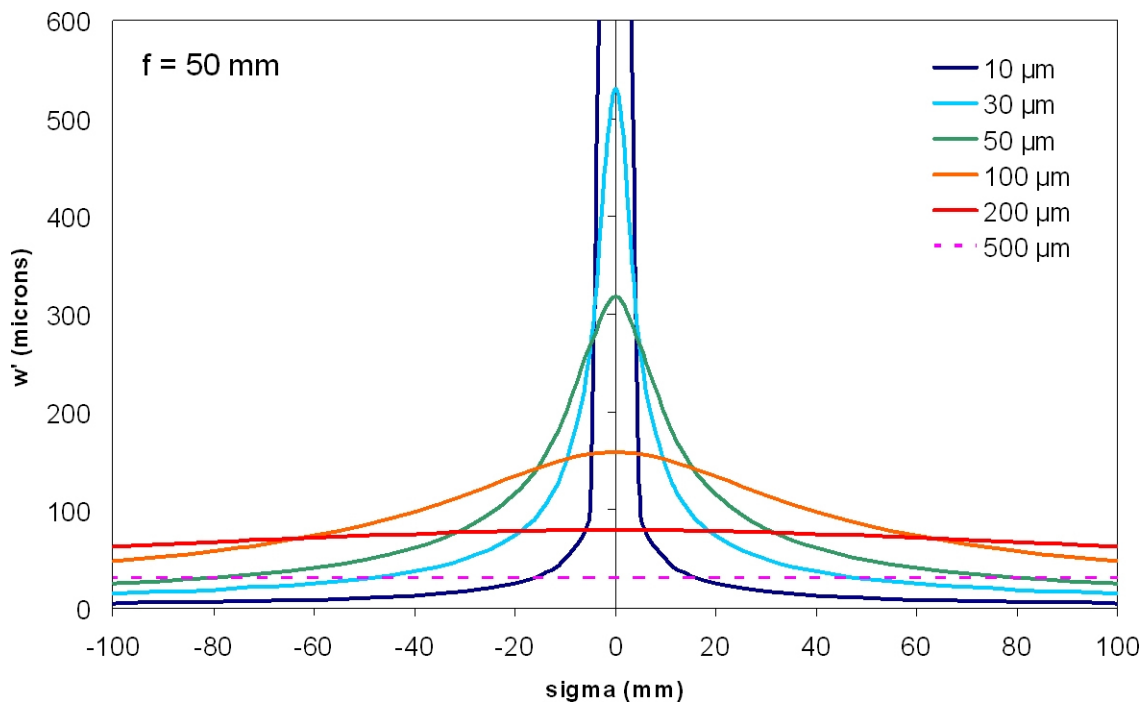
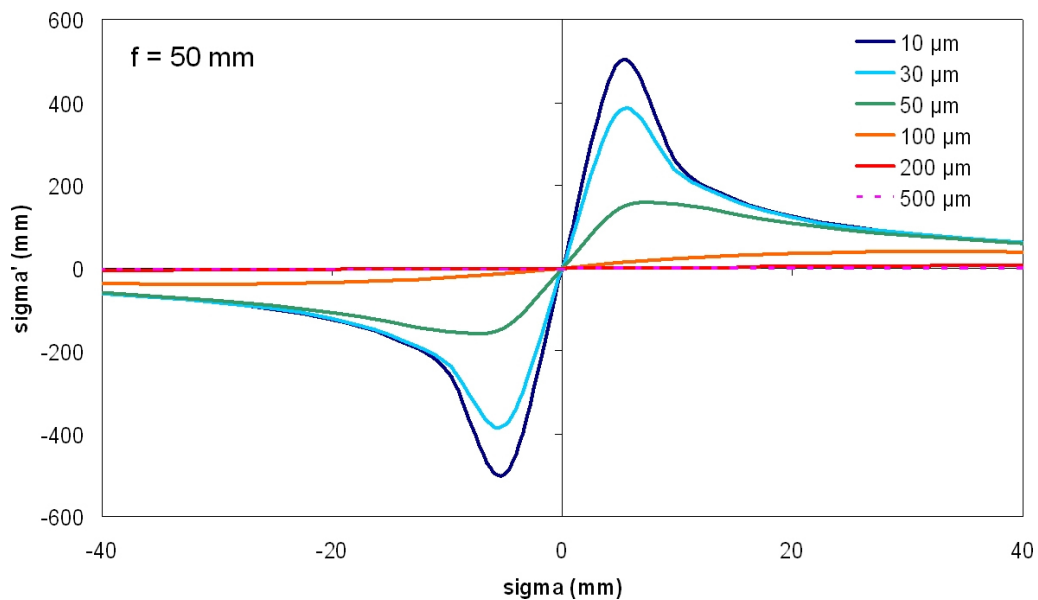

After observation of the figures 14 and 15 (illustrating the equations above), one can make the following comments :

- On the figure 14, when the size of the object waist is large, we have $\sigma' = 0$ for every value of σ : this is the geometric optics case, when a collimated beam is focused in the focal plan of a lens. The position of the object waist is not well-defined here as the Rayleigh distance is very big ("collimation" for large values of w).
- When the object waist size is very small, the observed behaviour is also similar to geometric optics, with asymptotic limits given by $\sigma\sigma' = f^2$.
- Besides those two cases, the difference with geometric optics is huge : for $w_0 = 10 \mu\text{m}$ and $\sigma = 0$ (small object waist located in the focal plane of the lens), the image waist is in the image focal plane, and not positioned to infinity as we learn from ray optics!
- This "paradox" is explained by the figure 15 : for $w_0 = 10 \mu\text{m}$ and $\sigma = 0$, the image waist is actually in the image focal plane but its size is very big : the beam is quasi-collimated and we find a behaviour similar to what is expected from geometric optics.

4. Fundamental Gaussian mode and laser resonator

4.1. ABCD law and Gaussian beams

For a stable cavity mode, the transverse structure of the beam as well as its phase (modulo 2π) remains the same after a round trip in the resonator.

More precisely, the complex radius of curvature $q(M)$ has to be conserved whatever the M

point may be. In other words, if $T(M) = \begin{pmatrix} A & B \\ C & D \end{pmatrix}$ is the transfer matrix with M chosen as the origin (be careful, $T(M)$ is different for each M !), we must have for every M ($ABCD$ law) :

$$q(M) = \frac{Aq(M) + B}{Cq(M) + D}$$

This is a general condition that could be applied to every resonator.

If we identify the real and imaginary parts of this relation, we obtain two equations that define the geometry of the system (particularly the waist(s) position) and the resonant frequency of the cavity respectively.

The stability condition is also a consequence of the $ABCD$ law. We could actually write :

$$Cq^2 + (D - A)q - B = 0$$

or

$$B\left(\frac{1}{q}\right)^2 + (A - D)\frac{1}{q} - C = 0$$

thus

$$\frac{1}{q} = \frac{1}{2B} \left(D - A \pm \sqrt{(D - A)^2 + 4BC} \right)$$

but $1/q$ is also equal to

$$\frac{1}{R} - i \frac{\lambda}{\pi w^2}$$

The beam could only exist if w is finite. The imaginary part of $1/q$ should consequently be different from zero, which means that $(D - A)^2 + 4BC$ has to be strictly negative.

The T matrix being unitary, we have $AD - BC = 1$ and the condition could be written :

$$(D + A)^2 < 4 \text{ that is } -1 < \frac{A + D}{2} < 1 \text{ or } 0 < \frac{A + D + 2}{4} < 1$$

We find again **the stability condition** previously demonstrated in the framework of ray optics, but here it is important to notice that the inequality is a strict one : the limits are excluded, which means that the cases where $|A + D| = 2$ are unstable resonators for Gaussian beams.

The $ABCD$ law also defines the Gaussian beam characteristics in M :

$$R = \frac{2B}{D - A}$$

and

$$w^2 = \frac{\lambda}{\pi} |B| \left[1 - \left(\frac{A + D}{2} \right)^2 \right]^{-\frac{1}{2}}$$

M is often positioned at a cavity waist ($R = \infty$). We then have $A = D$ in $T(M)$. Inversely, if we find $A = D$ then it means that M was located at a cavity waist.

4.2. Two-mirrors resonator

a) Introduction

We will discuss in details in this part the classical and very common resonator made of two spherical mirrors (radii of curvature R_1 and R_2 , separated by a distance d)

b) Resonator geometry

If a Gaussian beam is a mode for such a resonator, then its radius of curvature at the mirrors position matches the radius of curvature of the mirrors. This condition is necessary to insure that the beam returns the same way after bouncing on one mirror.

Let z_1 and z_2 be the M_1 and M_2 mirrors positions respectively : we have then $R(z_1) = -R_1$ et $R(z_2) = R_2$.

Remarque

The conventions used for the radii's signs are important : here we take $R > 0$ for a diverging wave and $R < 0$ for a converging wave, the positive direction being oriented from left to right (see figure 16).

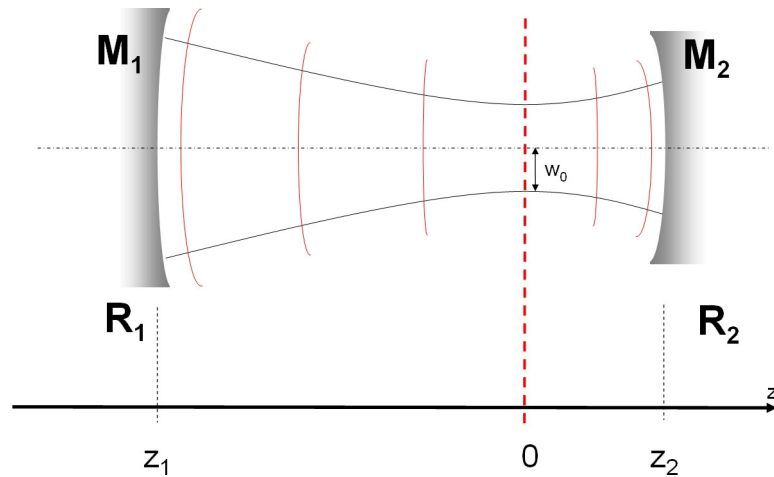

We can then make use of this characteristic to determine the mode geometry inside the cavity without using the general $ABCD$ law : we only need to apply the relations we already demonstrated in the "Gaussian spherical wave" paragraph, with the origin located at the waist. We then write the two conditions on the mirrors :

$$-R_1 = R(z_1) = z_1 \left[1 + \left(\frac{\pi w_0^2}{\lambda z_1} \right)^2 \right] = z_1 + \frac{Z_R^2}{z_1}$$

and

$$R_2 = R(z_2) = z_2 + \frac{Z_R^2}{z_2}$$

We also have $z_2 - z_1 = d$. We then just need to solve this 3 equations / 3 unknowns (z_1, z_2 and Z_R) system to obtain their values as a function of the distance d between the mirrors and their radii of curvature.

If we do the whole calculation (do it as an exercise !), and with $g_i = 1 - \frac{d}{R_i} (i = 1, 2)$, we come to the following relations :

$$z_1 = \frac{d(d - R_2)}{R_1 + R_2 - 2d} = \frac{-d g_2 (1 - g_1)}{g_1 + g_2 - 2 g_1 g_2}$$

$$z_2 = \frac{d(R_1 - d)}{R_1 + R_2 - 2d} = \frac{d g_1 (1 - g_2)}{g_1 + g_2 - 2 g_1 g_2} = z_1 + d$$

$$z_R^2 = \frac{d(R_1 + R_2 - d)(R_1 - d)(R_2 - d)}{(R_1 + R_2 - 2d)^2} = \frac{d^2 g_1 g_2 (1 - g_1 g_2)}{(g_1 + g_2 - 2 g_1 g_2)^2}$$

$$w_0 = \sqrt{\frac{\lambda}{\pi}} \left[\frac{d(R_1 + R_2 - d)(R_1 - d)(R_2 - d)}{(R_1 + R_2 - 2d)^2} \right]^{\frac{1}{4}} = \sqrt{\frac{\lambda d}{\pi}} \left[\frac{g_1 g_2 (1 - g_1 g_2)}{(g_1 + g_2 - 2g_1 g_2)^2} \right]^{\frac{1}{4}}$$

We can find here again the stability condition for a two-mirrors resonator, namely $0 < g_1 g_2 < 1$ with strict inequalities this time.

To generalize the stability diagram shown on figure 7 so that it could be applied to Gaussian beams, one then need to exclude the hyperbola itself as well as the $g_i = 0$ axis.

The simplest example is the Fabry P erot resonator, made of two facing plane mirrors. As the A and D matrix elements are equals to unity, we have $g_1 = g_2 = 1$: the stability condition is verified in ray optics, but not for Gaussian beams.

Nevertheless, it is possible to obtain stable laser operation with such a cavity, as some other elements could stabilize the resonator. For example, the amplifying medium itself often acts as a converging lens under pumping (thermal lensing).

c) TEM₀₀ modes frequencies

A mode could resonate if the field is the same after a round trip inside the cavity. In other words, the phase variation along this round trip has to be equal to a multiple of 2π ;

The phase term for a gaussian spherical wave is $e^{-ikz} e^{i\zeta(z)}$ (see the corresponding paragraph) where $\tan \zeta = z/Z_R$. The first exponential term is simply the phase shift due to propagation, whereas the second one is a specificity of Gaussian beams.

If $\phi(z)$ is the phase at the abscissa z , we should have :

$$\Delta \phi = \phi(z_2) - \phi(z_1) = -k(z_2 - z_1) + [\zeta(z_2) - \zeta(z_1)] = -q\pi$$

q is here an integer equal to the number of half-wavelengths over a distance d (nothing to do with complex radius of curvature here !): there is $(q - 1)$ nodes et q antinodes in the cavity (NB : for standard cavity lengthes (between one centimeter and one meter), q is a huge number !)

The resonant frequency of TEM_{00q} Gaussian modes in the cavity are consequently (replace k by $2\pi\nu/c$) :

$$\nu_q = \frac{c}{2d} \left[q + \frac{1}{\pi} \left(\arctan\left(\frac{z_2}{Z_R}\right) - \arctan\left(\frac{z_1}{Z_R}\right) \right) \right]$$

This expression could be written differently thanks to

$$\arctan(a) + \arctan(b) = \arctan\left(\frac{a+b}{1-ab}\right)$$

that is (after some calculations) :

$$\nu_q = \frac{c}{2d} \left[q + \frac{1}{\pi} \arccos(\pm \sqrt{g_1 g_2}) \right]$$

Remarque

g_1 and g_2 have the same sign because of the stability criterion. If this sign is positive, one should take the + sign in the formula, and vice-versa.

A very similar formula was given for a plane wave in the “longitudinal and transverse modes” paragraph : however we have here an additional term $\frac{c}{2d} \left[\frac{1}{\pi} \arccos \left(\pm \sqrt{g_1 g_2} \right) \right]$. This term is added for each frequency, so that we still have : $\Delta\nu_q = c/2d$.

The previous study was performed in the simple case of the two-mirrors linear cavity. For more complex resonators (see figures 17 and 18), we have to calculate the phase variation for each Gaussian beam during a round trip.

4.3. Other resonators

The detailed calculation was done for the two-mirrors cavity. In numerous cases, this geometry is not the best choice to get the desired laser.

Three-mirrors cavities (see figure 17) are widespread : it is possible for example with such resonators to benefit from a collimated beam in one branch of the cavity, which is very useful when one wants to add optical elements inside the resonator (Lyot filter, polarizing optics...)

It could also be desirable to have two waists in the resonators, with different sizes : one is used to put the amplifying medium, the other for example for a saturable absorber (Q-switch laser operation) or a non-linear crystal (frequency mixing). 4-mirrors geometries such as the one depicted on figure 17 are then a good choice.

Finally, one can imagine intricate cavities with several laser and/or non-linear crystals to mix several wavelengths (figure 18 is a beautiful example) : the only limit is in laserist's minds...

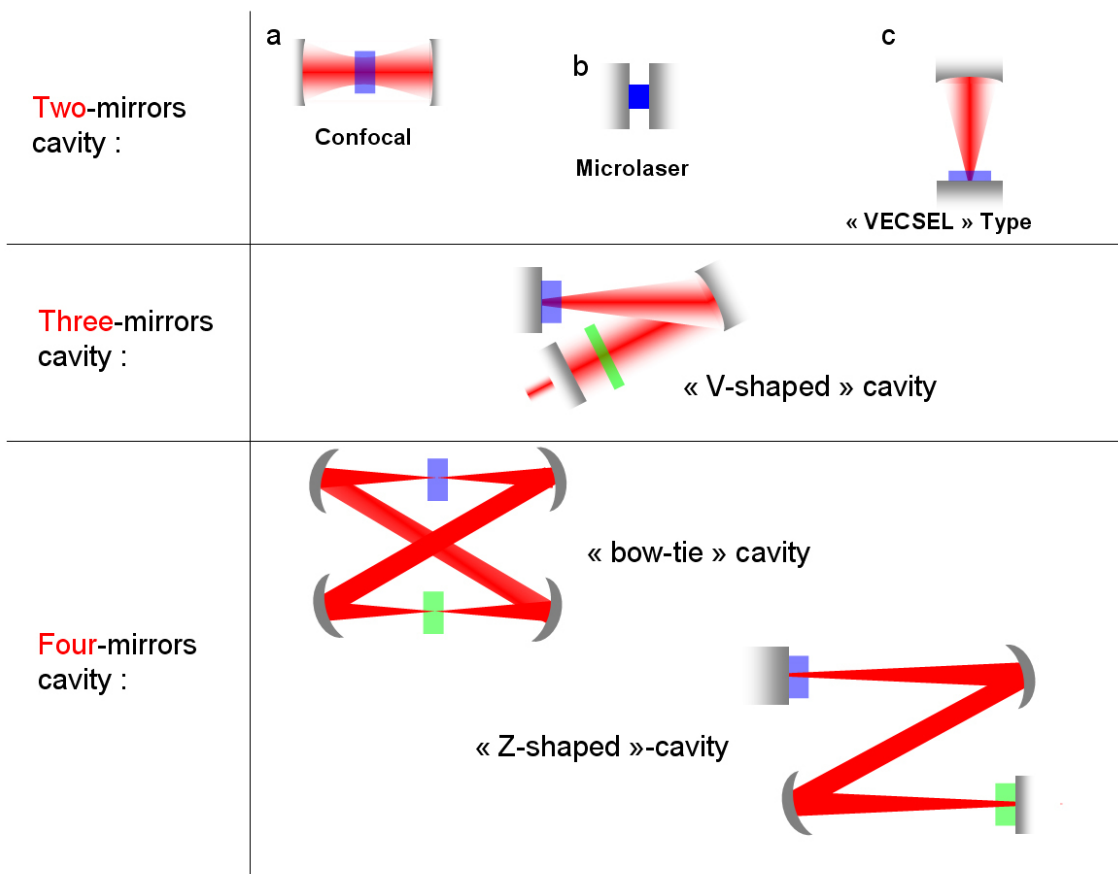

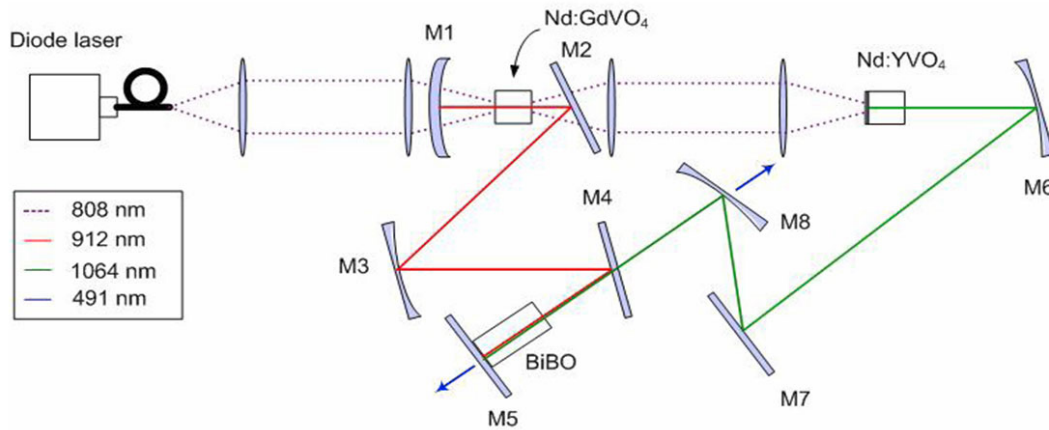

From Emilie Hérault PhD dissertation (Laboratoire Charles Fabry, Institut d'Optique)

5. High order modes

We considered in the previous sections a single solution of the paraxial wave equation, namely the fundamental Gaussian mode. Other solutions, mathematically forming an orthonormal and complete base, exist. Each oscillation in the resonator is a linear combination of those modes. Their transverse structures have a rectangular, cylindrical, or a mix of them symmetry : it is mainly defined by the mirrors shape (rectangular or circular). This structure is in general strongly affected by other perturbations and cannot be observed so easily.

5.1. Hermite-Gaussian Modes

a) Electromagnetic field structure

Let's start with the modes having a rectangular geometry in a Cartesian coordinates system. We can then write a solution of the wave equation as follows :

$$\psi(x, y, z) = g\left(\frac{x}{w}\right)h\left(\frac{y}{w}\right)e^{-i[\Delta\phi(z) + \frac{k}{2q(z)}(x^2 + y^2)]}$$

where g (respectively h) is a function of z and x (respectively z and y).

The insertion of this solution inside the paraxial wave equation leads to a differential equation for g and h : the solutions of this equation are Hermite's polynomials.

One can show (not demonstrated here) than a complete set of solutions is :

$$E_{mn}(x, y, z) = \sqrt{\frac{2}{\pi}} \frac{1}{2^{m+n}} \frac{1}{m!n!} \frac{1}{w(z)} H_m\left(\frac{\sqrt{(2)}x}{w(z)}\right) H_n\left(\frac{\sqrt{(2)}y}{w(z)}\right) e^{-i(kz - \phi(z))} e^{-i\left(\frac{k}{2q}\right)(x^2 + y^2)}$$

where :

- m, n are integers

- q, R et w were already defined for Gaussian beams (no change)
- $\phi(z) = (m + n + 1) \arctan \left(\frac{\lambda z}{\pi w_0^2} \right)$
- $H_m(X) = (-1)^m e^{X^2} \frac{\partial^m}{\partial X^m} e^{-X^2} = m! \sum_{p=0}^{\frac{m}{2}} \frac{(-1)^p}{p!(m-2p)!} \frac{(2X)^{m-2p}}{2^p}$: m-order Hermite polynomials
- As an example : $H_0(X) = 1, H_1(X) = 2X, H_2(X) = 4X^2 - 2$ etc.
- For $m = n = 0$, we have the fundamental Gaussian beam.
- For any m and n , the propagation law for R, q and w remains the same. Only the phase shift and the transverse beam structure differ.

The figures 19 and 20 depict the intensity pattern for those modes. One can notice some "zeros" for the intensity (dark lines) : their number correspond to the order m .

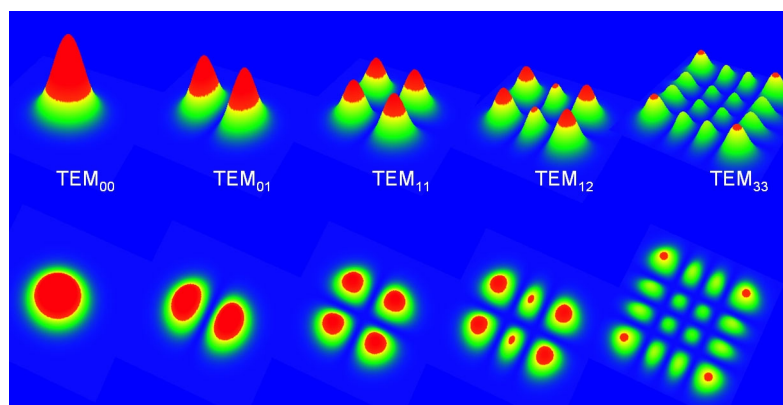
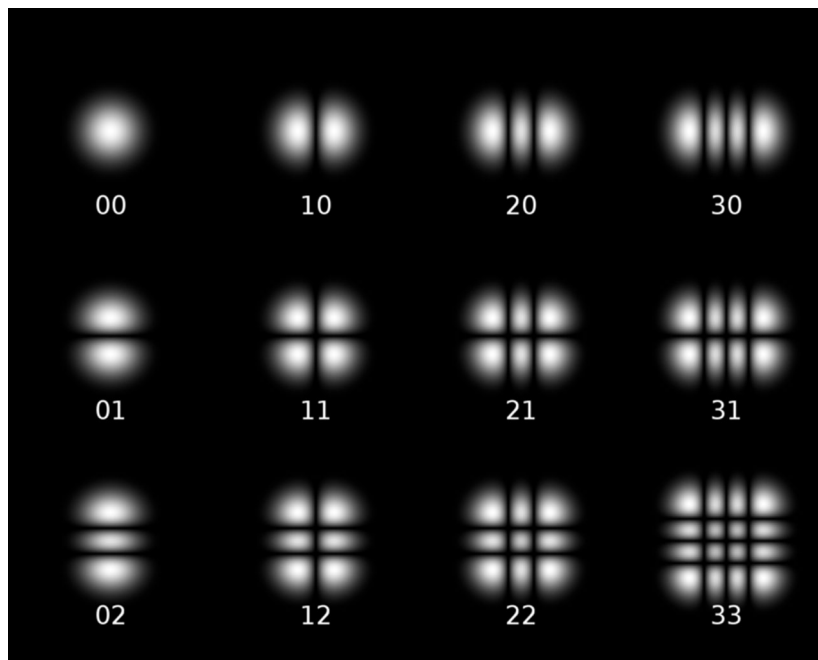

b) Frequency spectrum for a two-mirrors resonator.

The phase-shift after one round trip in a two mirrors resonator has to be equal to p times 2π (p is an integer). Starting from the phase expression $e^{-i(kz-\phi(z))}$ and using the same method as in paragraph "TEM₀₀ mode frequencies" we obtain the following expression for the frequency of the TEM_{mnq} mode:

$$\nu_{mnq} = \frac{c}{2d} \left[q + \frac{1}{\pi} (m+n+1) \arccos(\pm \sqrt{g_1 g_2}) \right]$$

$g_i = 1 - d/R_i$ was previously defined for a two-mirrors cavity (length d , radius of curvature R). $m = n = 0$ of course leads to the same expression as before for the fundamental Gaussian beam.

The frequencies depend on the values of the radii of curvature :

- For an almost plano-plano configuration ($R_1 = R_2 \gg d$) :

$$\arccos(g) \approx \sqrt{\left(\frac{2d}{R}\right)} \ll 1$$

The arccos term becomes $\arccos(g)$ and g is almost 1 so : . The ν_{mnq} frequencies are very close from ν_{00q} frequencies. The spectral intervalle $\delta\nu$ for $\Delta m = 1$ or $\Delta n = 1$

is equal to $\frac{1}{\pi} \sqrt{\left(\frac{2d}{R}\right)} \frac{c}{2d}$ (around some tens of MHz).

- For a quasi-confocal symmetrical resonator ($R_1 = R_2 = d$) the spectral gap between consecutive modes is $c/4d$ and the frequencies are degenerated (a longitudinal mode and some transverse modes have the same frequencies).

5.2. Laguerre-Gaussian Modes

If the resonator symmetry is mostly circular, the modes exhibit a cylindrical symmetry described by the Laguerre polynomials. The mathematical method is the same as the one described for Hermite-Gaussian modes. The figure 21 describe the intensity distribution for such modes.

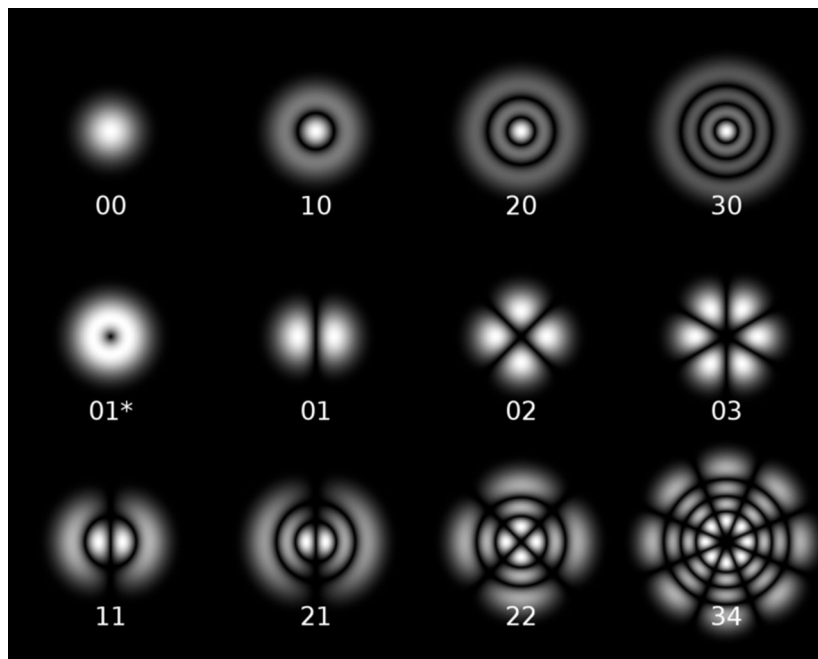

5.3. Multimode beams propagation and M^2 factor.

The spatial extension of any given mode is always bigger than the fundamental mode one. We can then define a M coefficient, greater than one, such as :

$$w_{mn}(z) = M w_{00}(z)$$

where w_{mn} et w_{00} are the waists of the observed beam and the fundamental beam, respectively. By injecting this equation in the complex radius of curvature definition, we obtain :

$$\frac{1}{q(z)} = \frac{1}{R(z)} - i \frac{M^2 \lambda}{\pi w_{mn}^2}$$

All the previously demonstrated formulae are then the same, but with $M^2 \lambda$ instead of λ everywhere. For $M^2 = 1$, we obviously find the relationships obtained for the fundamental Gaussian mode.

The « M^2 factor » is a kind of measurement of the "degradation" of the beam quality compared to the fundamental Gaussian beam, taken as reference.

Définition

More precisely, M^2 could be experimentally defined by the following sentence : "for a given waist, the measured divergence of the studied beam is M^2 times bigger than the divergence of the fundamental Gaussian beam" or :

$$\theta = M^2 \frac{\lambda}{\pi w_0} = M^2 \theta_{00}$$

where $\lambda/\pi w_0$ is the divergence of a TEM_{00} mode with the same waist as the observed beam.

Practically, high order Hermite or Laguerre beams are rarely observed. It is however frequent to deal with "single-lobe" beams with a quasi circular shape and Gaussian-like energy distribution : the M^2 factor characterize in this case "how far" from a TEM_{00} you are : it is a measure of the difference between a real beam and the theoretical limit given by the diffraction.

From an experimental point of view, the principle of the measurement is as follows : one had to measure the divergence of the beam together with the waist w_0 , and then compare the result to $\lambda/\pi w_0$: the ratio will give M^2 .

Technically, you have to focus the studied beam with a converging lens, and then to measure the size w of the beam for different positions along the z -axis with any suitable method (camera imaging, measure of the energy percentage passing through an iris...). You will finally obtain a curve similar to the one depicted on the figure 11 : you can fit this curve with the formula that gives $w(z)$ (with the M^2 factor of course set as the free parameter),

The beams produced by He-Ne lasers or low power diode pumped solid state lasers are usually diffraction limited ($M^2 = 1$ or less). For high power lasers (for example flash-pumped Nd:YAGs), the transverse structure is often heterogeneous and the M^2 factor easily reaches values between 2 and 10. The beams could also sometimes suffer from astigmatism, so that the M^2 factor is not the same in the x and y directions. Finally, for non-Gaussian beams (for example beams from high power laser diodes) we can have M^2 factors values above 50, even if the physical signification of this widely used parameter has to be discussed in this case...

* *

*

The resonators study is a necessary first step for any laser realization. In this course, we only described simple passive structures : for more complex systems, several software have been developed to easily simulate any type of cavity without carrying simple but painful calculation. It is then possible to take into account some more complex effects such as :

- influence of the finite size of the mirrors : the diffraction plays a key role if the mirrors are very small. In this case the relevant term is the Fresnel' s number $N = \frac{a_1 a_2}{\lambda d}$ where a_1 and a_2 are the cavity mirrors radii (not the radii of curvature !). If $N \gg 1$, you could neglect the diffraction effects.
- Astigmatism for the off-axis systems (as V-shaped cavities for example)
- Influence of the amplifying medium (active cavity) : heating effects, dynamic behaviour...
- Polarization effects

For a more complete review on the topic I suggest the following references : [[Lasers] , [Laser Beams and resonators]]

III. Case study

The aim of this part is to study in practical terms a classical laser resonator such as the one described in the course "principle of laser". This study is also useful to apply the notions of the present course to a "real" case.

Let us remind the geometry of the resonator and the different parameters we will use during the study :

- a Nd:YAG crystal (length $l = 10 \text{ mm}$, refractive index $n = 1,8$) is the amplifying medium in a two-mirrors linear cavity.
- One mirror is directly coated on the crystal (this mirror is obviously a plane mirror) : the coating is HT (High Transmission) at the pump wavelength (808 nm), and HR (High Reflection) at the laser wavelength (1064 nm). Let A_1 be the reflection coefficient around 1064 nm: A_1 is close to unity. This mirror is made from a high number of very thin layers of low and high index materials: with this type of "dielectric coating", almost every spectral shape could be given to the reflection coefficient.
- The other mirror has a radius of curvature R and is used to close the cavity. Its coefficient of reflection at 1064 nm (A_2) is below unity to let the laser beam escape from the resonator.
- The distance between the uncoated end of the crystal and the output coupler is L . The total length of the resonator is consequently $L + l$ (see figure).

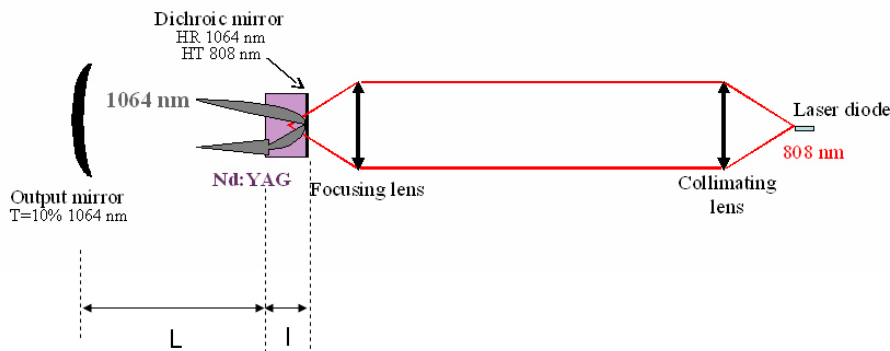

1. Preliminary study of the hemispheric resonator

1.1. Stability

Let us write the $ABCD$ matrix for a round trip, which could be broke up as follows (see figure 2) :

- a first path in air, over a distance L
- a path in the crystal (refractive index n) over a distance l
- The reflection on the plane mirror (no impact on the calculation)
- Again, one path in the crystal and another in air.
- Finally the reflection on the output coupler (radius of curvature R)

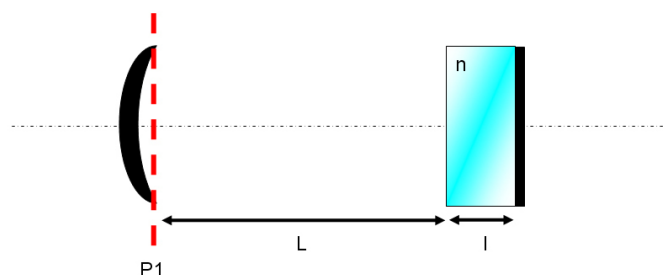

The unfolded cavity is presented in the figure 3 and correspond to the following sequence of matrices (the order is important !):

$$T = \begin{pmatrix} 1 & 0 \\ -\frac{2}{R} & 1 \end{pmatrix} \begin{pmatrix} 1 & L \\ 0 & 1 \end{pmatrix} \begin{pmatrix} 1 & \frac{l}{n} \\ 0 & 1 \end{pmatrix} \begin{pmatrix} 1 & \frac{l}{n} \\ 0 & 1 \end{pmatrix} \begin{pmatrix} 1 & L \\ 0 & 1 \end{pmatrix}$$

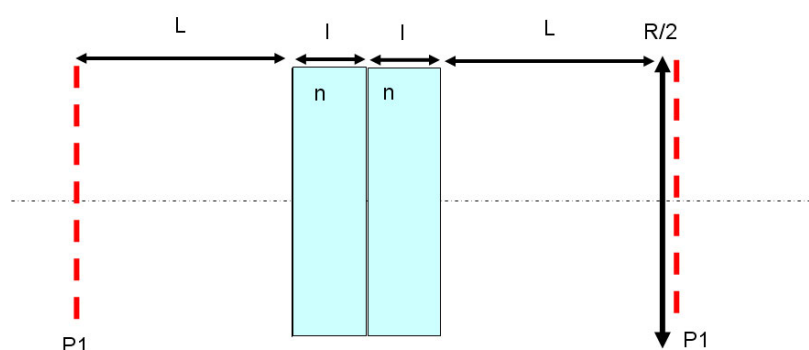

with $d = L + l/n$ to make the notations lighter, we find after simple calculations :

$$T = \begin{pmatrix} 1 & 2d \\ -\frac{2}{R} & 1 - 4\frac{d}{R} \end{pmatrix}$$

The resonator is stable if $0 < \frac{A + D + 2}{4} < 1$ or :

$0 < 1 - \frac{d}{R} < 1$ as d/R is obviously positive so the condition reduces to :

$d < R$ soit en reprenant les notations de base $L < R - \frac{l}{n}$

Remarque

For an "empty" cavity (without crystal), with a length L_{eq} , the stability condition was defined in the course as $0 < g_1 g_2 < 1$. As $g_1 = 1 - L_{eq}/R_{plan} = 1$ because R_{plan} is equal to infinity, the condition becomes $g_2 = 1 - \frac{L_{eq}}{R} > 0$ or $L_{eq} < R$.

From the stability point of view, the real cavity with the crystal is then equivalent to an empty cavity with an equivalent length $L_{eq} = d = L + \frac{l}{n}$.

Attention

The equivalent length does not correspond to the optical length $L + nl$!

Let's go back to our resonator : any couple (radius of curvature R - length L) is suitable as soon as the condition $L < R - \frac{l}{n}$ is verified. From a practical point of view, other considerations such as the optimum size of the waist inside the crystal will impact this choice. Moreover, we generally do not have in the lab an infinite choice for the radii of curvature of the mirrors !

For the moment, let us pick in the lab a mirror with appropriate coatings and a radius of curvature $R = 100$ mm.

The length L must then be shorter than $100 - 10/1,8 \approx 94,5$ mm.

We will take for example in the following $L = 80$ mm.

1.2. Beam profile inside the resonator

We have fixed the cavity length to keep it stable. Now we will look in details at the beam profile inside the resonator.

We already know that the **waist will be located on the plane mirror** : the beam has to bounce back on itself.

Let us first determine the size of the beam on each mirror (w_0 on the plane mirror and w_1 on the spherical one), as well as the beam's divergence and the associated Rayleigh length Z_R :

A simple approach is to work with the equivalent resonator (see above), with a length $L_{eq} = d = L + \frac{l}{n}$.

If $z = 0$ is taken on the plane mirror, we can write that for $z = d$ (that is on the spherical mirror) the radius of curvature of the laser beam is the same as the radius of curvature of the spherical mirror (to ensure that the beam bounces back on the same way). But we know how R varies with z (see course), so that we can write :

$$R = R(z=d) = d \left[1 + \left(\frac{\pi w_0^2}{\lambda d} \right)^2 \right] = d \left[1 + \left(\frac{Z_R}{d} \right)^2 \right]$$

we then easily deduce that :

$$Z_R = \sqrt{d(R-d)} = \frac{\pi w_0^2}{\lambda}$$

with $d = L + l/n = 80 + 10/1,8 = 85,5$ mm and $R = 100$ mm, we obtain :

$Z_R = 35,2$ mm and $w_0 = 110 \mu\text{m}$ (the wavelength is 1064 nm)

The divergence is $\theta = \frac{\lambda}{\pi w_0}$ which is equal to 3 mrad.

To obtain the beam waist on the output coupler, we only need the following formula :

$$w(z) = w_0 \sqrt{1 + \left(\frac{\lambda z}{\pi w_0^2} \right)^2}$$

which leads for $z = d$ to :

$$w_1 = \sqrt{\left(\frac{\lambda R}{\pi}\right) \left(\frac{d}{R-d}\right)^{\frac{1}{4}}}$$

or $w_1 = 286 \mu\text{m}$.

The beam profile inside the resonator is consequently depicted on figure 4 :

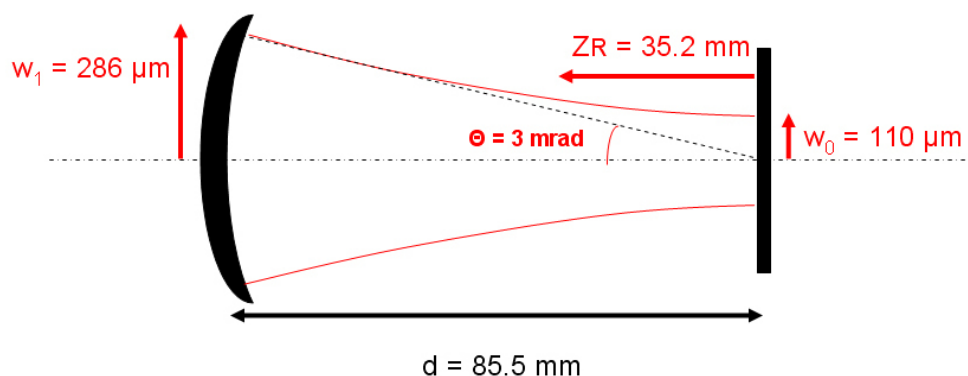

2. "Real life" resonator

2.1. Optimisation of the cavity

We have obtained in the previous paragraph the characteristics of the beam for a specific value of L .

In most cases, the pumping conditions impose a given value for the waist, and consequently fix the resonator geometry. For example, in the course entitled "principles of lasers", the pumping geometry (through the use of a $1 \times 100 \mu\text{m}$ laser diode) leads to a fixed value for the pumping waist : it is focused in this specific case on a $20 \times 100 \mu\text{m}$ spot. To simplify the calculations, we will here suppose that this spot is circular (which is the case when using fiber coupled laser diodes) with a $80 \mu\text{m}$ radius inside the laser crystal.

A crucial point is to match the laser mode with the pump mode size : we will try to get a laser mode size compatible with the pump spot size. More precisely, we will choose a laser mode slightly smaller than the pump mode, in order to benefit for an homogeneous pumping over all the laser mode area.

As an example, we will then try to have $w_0 = 60 \mu\text{m}$.

Remarque

A more detailed analysis to obtain the optimal mode-matching is beyond the scope of this course.

What is the length L in this case (always with our $R = 100 \text{ mm}$ output coupler) ?

With the formula $Z_R = \sqrt{d(R-d)} = \frac{\pi w_0^2}{\lambda}$, we get a trinomial :

$$d^2 - dR + \left(\frac{\pi w_0^2}{\lambda}\right)^2 = 0$$

Solving this trinomial gives two values for d :

$$d_1 = 98,85 \text{ mm and } d_2 = 1,14 \text{ mm.}$$

Of course only the first solution makes sense (for the other one, L is negative) and leads to $L = 93,3 \text{ mm}$.

We are still in the stability zone, but near the frontier.

We can plot (figure 5) the evolution of the waist w with L for a given value of R (here 100 mm). Of course for $L > R$ the resonator is unstable and we cannot define any waist.

There is a zone for L around $R/2 = 50 \text{ mm}$ where the waist stays almost constant. We also notice that with our output coupler, it is not possible to get a laser waist bigger than $130 \mu\text{m}$. On the other hand, we can have very small waists near the stability limit.

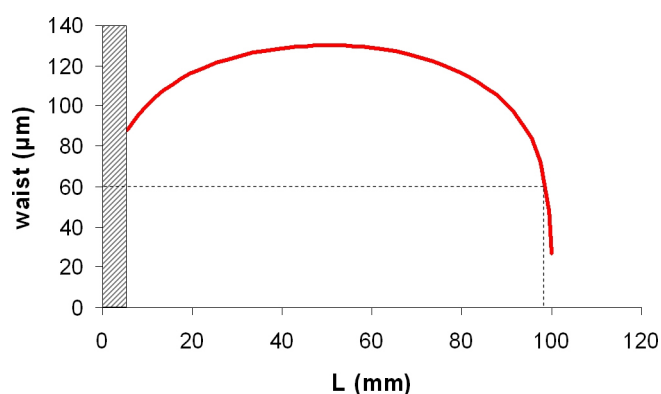

2.2. Output beam

From the experimentalist point of view, an interesting point is the profile of the beam outside the cavity, after the output coupler.

The outcoupling mirror is only partially reflective, and has a spherical side (inside the cavity, coated) and a plane one (outside the cavity, uncoated : this is just the rear face of the glass substrate).

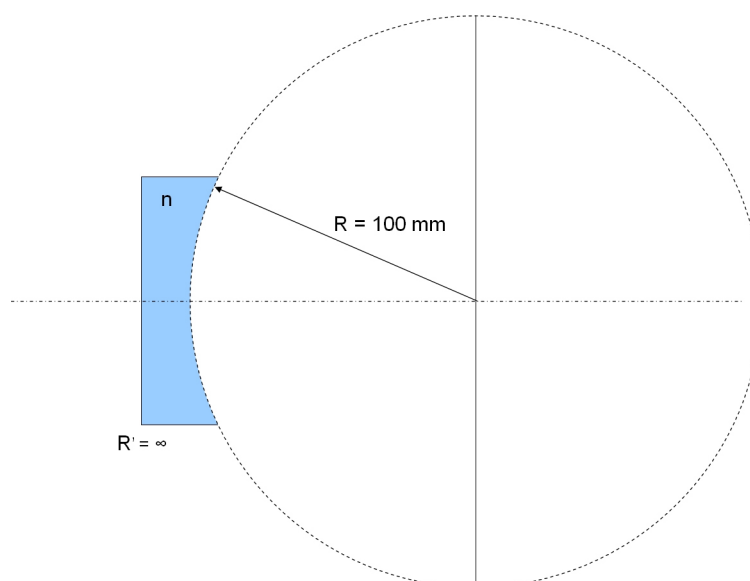

The output coupler consequently acts as a diverging lens for the escaping laser beam.

Its focal length f' is given by the following formula (see a course on ray optics) :

$$\frac{1}{f'} = (n_M - 1) \left(\frac{1}{R'} - \frac{1}{R} \right) \text{ with } R' = \infty \text{ and } n_M \text{ the refractive index of the substrate.}$$

We have then $f' = \frac{R}{(1 - n_M)}$, or with $n_M = 1,5$ (glass) : $f' = -200$ mm.

We calculated the beam divergence inside the cavity. But what is the result outside the cavity, for the useful beam ?

Let us have a look on the new complex radius of curvature after the output mirror (that is after a diverging lens with a focal length f'), and apply the $ABCD$ law :

$q(\text{after}) = \frac{Aq(\text{before}) + B}{Cq(\text{before}) + D}$ where $q(\text{before})$ is the complex radius of curvature before the mirror and $q(\text{after})$ is the complex radius of curvature after passing through the same mirror, The $ABCD$ coefficients are those of a simple lens transfer matrix :

$$T = \begin{pmatrix} 1 & 0 \\ -\frac{1}{f} & 1 \end{pmatrix}$$

we then deduce that :

$$\frac{1}{q(\text{after})} = \frac{1}{q(\text{before})} - \frac{1}{f'}$$

NB : this expression is often useful when one had to transform a Gaussian beam through a lens.

We also have $\frac{1}{q(\text{before})} = \frac{1}{R} - i \frac{\lambda}{\pi w_1^2}$ and $\frac{1}{q(\text{after})} = \frac{1}{R'} - i \frac{\lambda}{\pi w_1^2}$ (we suppose that the lens is a thin lens, so that the size of the beam does not change between the two faces of the lens).

We consequently have after identification $R' = R/n_M$.

We remind the following formula :

$$w_0^2 = \frac{w^2}{1 + \left(\frac{\pi w^2}{\lambda R} \right)^2}$$

with the new value of R' , we find the "effective" waist for the beam outside the cavity :

$$w_0'^2 = \frac{w_1^2}{1 + \left(\frac{\pi w_1^2 n_M}{\lambda R} \right)^2}$$

With the value of w_1 (see above) : $w_1 = \sqrt{\left(\frac{\lambda R}{\pi} \right) \left(\frac{d}{R-d} \right)^{\frac{1}{4}}}$ we find :

$$w_0'^2 = \frac{w_1^2}{1 + \left(\frac{dn_M^2}{R-d} \right)}$$

as we also have $w_1 = w_0 \sqrt{1 + \left(\frac{d^2}{Z_R^2} \right)}$ and $Z_R = \sqrt{d(R-d)}$ we obtain :

$$w_0'^2 = \frac{R w_0^2}{R + (n_M^2 - 1) d}$$

So that the new divergence θ' is given by :

$$\frac{\theta'}{\theta} = \frac{w_0}{w_0'} = \sqrt{1 + (n_M^2 - 1) \frac{d}{R}}$$

From a numerical point of view, the divergence after the output mirror is 1,438 bigger than the divergence inside the resonator (for $d = 85,5$ mm – see figure 4) that is 4,3 mrad.

2.3. Thermal lensing effects

Let us get closer to real life : during the pumping, a lot of energy is gathered on a very small area inside the crystal. This leads to local heating, and as the refractive index varies with temperature, an index gradient appears. In the same time, the thermal dilatation of the crystal leads (in most cases) to a kind of bulge of the crystal. This last effect transforms for example the plane mirror into a spherical one.

The index gradient could be simulated in a first approximation by a converging (in most cases, but sometimes it could be a diverging one) lens positioned at the pump focusing point inside the crystal.

We will not here perform the calculations : it is fastidious and does not add anything to the lesson as the principle is exactly the same as before (but with more lenses inside the cavity !)

Fortunately, this kind of matrix calculation is a very simple game for computers and several software (some of them are even free !) exist on the market.

We can then get as close as possible to real resonators (other points can be taken into account : absorption, polarization...) and accurately predict the beam characteristics before building the laser.

3. Longitudinal and transverse modes

3.1. Longitudinal and transverse modes

We will in this final part calculate the frequencies of the longitudinal modes of the resonator : the phase shift for a single pass in the resonator is equal to (see course) :

$$\Delta \phi = \phi(d) - \phi(0) = -k(D) + [\zeta(d) - \zeta(0)] = -q\pi$$

with $k = 2\pi \frac{\nu}{c}$, D the optical path ($D = L + nl$), $\tan \zeta(0) = 0$, and $\tan \zeta(d) = \frac{d}{Z_R} = \sqrt{\left(\frac{d}{R-d}\right)}$.
Consequently :

$$\nu_q = \frac{c}{2D} \left[q + \frac{1}{\pi} \left(\arctan \sqrt{\left(\frac{d}{R-d}\right)} \right) \right]$$

and for the transverse modes :

$$\nu_{mnq} = \frac{c}{2D} \left[q + \frac{m+n+1}{\pi} \left(\arctan \sqrt{\left(\frac{d}{R-d}\right)} \right) \right]$$

We find with $L = 80$ mm a 1,5 GHz gap between two consecutive longitudinal modes and 575 MHz between the fundamental mode and the first transverse mode (see figure 7).

Remarque

For a lasing wavelength in the near infrared (1064nm), this leads to a value of q around $1,195 \cdot 10^8$.

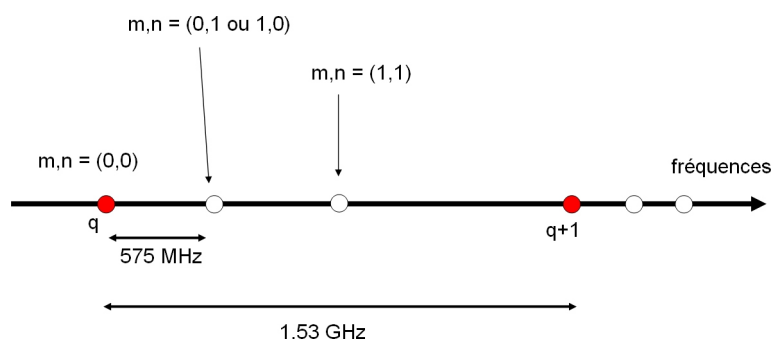

IV. Lesson questions

1. Laser beam transformation

We want to use a thin lens in order to focus a collimated beam (radius 1 mm, from an He-Ne laser, wavelength = 633 nm) so that the Rayleigh length is 30 nm.

Question

[Solution n°1 p 44]

What focal length should have the lens ?

2. Laser beam characteristics

Let us work with an "hemiconfocal" resonator with an effective length d , made of two mirrors (one is plane, the other has a $R = 2d$ radius of curvature)

Question 1

[Solution n°2 p 44]

Show that this resonator is stable.

Question 2

[Solution n°3 p 44]

What are the geometrical characteristics of the laser beam inside the cavity (waists on each mirrors, Rayleigh length, divergence) ?

3. Stability

A resonator is composed of two mirrors, one concave and one convex, with radii of curvature 1,5 m and -1 m respectively. The distance between them is d .

Question

[Solution n°4 p 44]

In what range could we choose d so that the cavity remains stable ?

4. Energy

A given Gaussian laser beam is characterized by its waist w .

Question

[Solution n°5 p 45]

What is the percentage of energy transmitted through a circular aperture having a radius ρ and centered on the beam?

Numerical application : $\rho = 0,5w$; $\rho = 0,75w$; $\rho = w$; $\rho = 2w$

5. Spectral distribution of the longitudinal modes

We have an He-Ne laser, with a 20 cm long cavity, lasing at 632,8 nm.

Question 1

[Solution n°6 p 46]

What is the frequency (and wavelength) gap between two consecutive longitudinal modes ?

Question 2

[Solution n°7 p 46]

We want to use a spectral filter with a bandwidth of **1 nm**. What value should we choose for the cavity length to select one (and only one !) longitudinal mode with this filter ?

Solution des exercices

>Solution n°1 (exercice p. 42)

We want $Z_R = \frac{\pi w'^2}{\lambda} = 30 \text{ mm}$ which means for a 633 nm wavelength :
 $w' = 78 \mu\text{m}$

We know that in this particular case (when one of the waists is located on the focal point of the lens) we have $w' = \frac{\lambda f}{\pi w}$

Then

$$f = \frac{\pi w w'}{\lambda} = 387 \text{ mm}.$$

>Solution n°2 (exercice p. 42)

The stability condition for a two mirrors resonator is :

$$0 < g_1 g_2 < 1$$

with here $g_1 = 1 - \frac{d}{R_{\text{plan}}} = 1$; $g_2 = 1 - \frac{d}{R}$

The condition then becomes $d < R$ and is always true since $R = 2d$.

>Solution n°3 (exercice p. 42)

$$R = 2d = d \left(1 + \frac{Z_R^2}{d^2} \right)$$

because the wavefront radius of curvature on the mirror has to be equal to the mirror radius of curvature Consequently

$$Z_R = d = \pi \frac{w_0^2}{\lambda} ; w_0 = \sqrt{\lambda \frac{d}{\pi}} \text{ and } \theta = \frac{\lambda}{\pi w_0}.$$

>Solution n°4 (exercice p. 42)

The stability condition for a two mirrors resonator is : $0 < g_1 g_2 < 1$

which could also be written $0 > (R_1 - d)(R_2 - d) > R_1 R_2$

and finally :

$$R_1 + R_2 = 0.5 \text{ m} < d < 1.5 \text{ m} = R_2$$

>Solution n°5 (exercice p. 42)

The intensity profile is Gaussian :

$$I(r, z) = I_0(z) e^{-2 \frac{r^2}{w^2(z)}}$$

and r goes from zero to infinity.

The fraction of energy F passing through a circular aperture with a radius ρ is

$$F = \frac{\int_0^{\rho} I(r) dS}{\int_0^{\infty} I(r) dS}$$

with $dS = 2\pi r dr$

If we replace $I(r)$ by its Gaussian expression, we obtain after simplification

$$F = \frac{\int_0^{\rho} r e^{-2 \frac{r^2}{w^2}} dr}{\int_0^{\infty} r e^{-2 \frac{r^2}{w^2}} dr}$$

We can easily calculate this integral (using the variable $t = r^2$) :

$$\int_0^{\rho} r e^{-2 \frac{r^2}{w^2}} dr = \frac{1}{2} \int_0^{\rho^2} e^{-2 \frac{t}{w^2}} dt = \frac{1}{2} \left[\frac{-w^2}{2} e^{-2 \frac{t}{w^2}} \right]_0^{\rho^2}$$

Finally we find :

$$F = 1 - e^{-2 \left(\frac{\rho}{w} \right)^2}$$

Numerically speaking :

$r/w = 0,5$ leads to $F = 0,39$ $r/w = 0,5$ leads to $F = 0,39$

$r/w = 0,5$ leads to $F = 0,67$ $r/w = 0,75$ leads to $F = 0,67$

$r/w = 0,5$ leads to $F = 0,67$ $r/w = 1$ leads to $F = 0,86$

$r/w = 0,5$ leads to $F = 0,67$ $r/w = 2$ leads to $F = 0,999$

Complément

If the radius of the aperture is equal to the beam waist, only 86% of the energy is transmitted. This is because of the definition of the beam waist : it is the radius of the beam when the intensity is $1/e^2$ of its maximal value. All the energy contained in the "wings" of the Gaussian is consecutively lost with this aperture.

We also see with the above calculation that we need an aperture twice as large as the beam waist in order to get all the energy transmitted.

>Solution n°6 (exercice p. 43)

$$\Delta \nu_q = \frac{c}{2L} = \frac{3 \cdot 10^8}{0,4} = 750 \text{ MHz}$$

$$\frac{\Delta \lambda}{\lambda} = \frac{\Delta \nu}{\nu} \text{ then } \Delta \lambda = 1 \text{ pm}$$

>Solution n°7 (exercice p. 43)

We want that $\Delta \lambda > 0,5 \text{ nm}$ which can be written $\Delta \nu = \frac{c \Delta \lambda}{\lambda^2} > 3,75 \cdot 10^{11} \text{ Hz}$.

We deduce from this equation that L has to be less than $0,4 \text{ mm}$.

Bibliographie

[**Laser Beams and resonators**] KOGELNIK HERWIG, *Laser Beams and resonators*, Applied Optics, 1966Octobre-, Vol.5, pages 1550 et suivantes,.

[**Lasers**] SIEGMAN ANTHONY, *Lasers*, University Science Books, USA, 1990, Optical beams and resonators - ISBN-10: 0935702113.